

**A Reliable Method of Loudspeaker Rub and Buzz Testing Using Automated FFT
Response and Distortion Techniques**

3161 (S-1)

Gregory G. Groeper
Douglas Ordon and Company
Chicago, IL 60639-3428, USA

Mark A. Blanchard
Electro-Voice
Buchanan, MI 49107, USA

6M/S-1

Terry Brummett and Jeff Bailey
Harman-Motive
Martinsville, IN 46151, USA

**Presented at
the 91st Convention
1991 October 4–8
New York**



AES

This preprint has been reproduced from the author's advance manuscript, without editing, corrections or consideration by the Review Board. The AES takes no responsibility for the contents.

Additional preprints may be obtained by sending request and remittance to the Audio Engineering Society, 60 East 42nd Street, New York, New York 10165, USA.

All rights reserved. Reproduction of this preprint, or any portion thereof, is not permitted without direct permission from the Journal of the Audio Engineering Society.

AN AUDIO ENGINEERING SOCIETY PREPRINT

A RELIABLE METHOD OF LOUDSPEAKER RUB AND BUZZ TESTING USING AUTOMATED FFT RESPONSE AND DISTORTION TECHNIQUES

Gregory G. Groeper

Douglas Ordon and Company
4646 West McLean Avenue
Chicago, IL 60639-3428 USA

Mark A. Blanchard

Electro-Voice
128 East Front Street
Buchanan, MI 49107 USA

Terry Brummett & Jeff Bailey

Harman-Motive
1201 South Ohio
Martinsville, IN 46151 USA

Contents

0. ABSTRACT	Page 2
1. INTRODUCTION	Page 2
2. WHAT KIND OF LOUDSPEAKERS?	Page 3
3. WHAT GOES WRONG?	Page 3
4. ON EVALUATION TECHNIQUES	Page 5
5. ON TESTING - "LISTENER" CONVENTIONS	Page 5
6. ON TESTING - EQUIPMENT CONVENTIONS	Page 7
7. ON TESTING - ALTERNATIVES	Page 9
8. EXPERIMENT 1: EVALUATION OF HUMAN HEARING CHARACTERISTICS FOR USE IN LMA TESTING, THROUGH LISTENING TEST & FFT ANALYSIS OF A FLUTE, OBOE & LOUDSPEAKERS	Page 9
9. EXPERIMENT 2: SINGLE TONE STIMULUS & FFT ANALYSIS OF LMA	Page 12
10. "LoMAD" Loudspeaker Mechanical Anomaly Detection via "FASTest"®	Page 17
11. "LoMAD" TEST PROCEDURES	Page 20
12. "LoMAD" QC TESTING RESULTS	Page 21
13. CONCLUSIONS.....	Page 22
NOTICES & ACKNOWLEDGMENTS	Page 24
REFERENCES	Page 24
APPENDIX 1: PROJECT HISTORY/BACKGROUND	Page 26
APPENDIX 2: TEST SETUPS/EQUIPMENT USED	Page 27
APPENDIX 3: "LoMAD" SETUP PROCEDURE	Page 28
APPENDIX 4: "LoMAD" PRODUCTION LINE PROCEDURE	Page 31
GRAPHS & TABLES	Page G1-G30

0. ABSTRACT

0.1 By utilizing modern DSP technology and FFT spectral analysis, and by applying some aspects of human hearing and psychoacoustics, a reliable method of "rub" and "buzz" distortion testing for loudspeakers can be devised for a wide variety of engineering and production applications. Additionally, test times can be radically reduced, thus contributing favorably to outside noise rejection and a higher degree of repeatability.

0.2 Examples of test results include comparisons of good and bad units and feature standard cone type loudspeakers and compression drivers showing varying degrees of conformity. In the final analysis, loudspeakers are tested for polarity, frequency response and different types of distortion.

1. INTRODUCTION

1.1 Loudspeakers have direct impact on everyone. We rely on them for accurate reproduction of the music, words and sounds that are important to us. Furthermore, audio electronics have achieved a state-of-the-art where many of the performance limitations associated with these components are reduced to levels of practical insignificance. Thus, we are at a point where the final delivery mechanism can become the limiting factor in system performance. More than ever, the need to maintain a high quality standard for loudspeakers is clear.

1.2 To their credit, design and manufacturing engineers are constantly working to improve loudspeaker quality, with new ideas, techniques and materials. As a result, refinements in loudspeaker evaluation techniques have developed.

1.3 One loudspeaker test method makes use of individuals employed as live test equipment or "Listeners." The ear's sophistication and its ability to detect small levels of distortion make this a desirable technique for many. An experienced "Listener" can perform pass/fail listening tests on a production line with impressive results and maintain a test cycle time of 3 to 7 seconds per loudspeaker, a line rate common in many factories.

1.4 As ATE systems have become more common, techniques to automate this process have evolved. These typically employ specialized analog audio test systems under some type of computer control. While these systems differ from the ear in their analysis techniques, they have become quite sophisticated. In addition to providing pass/fail testing, they offer the added benefits associated with computerized ATE/data acquisition systems. Depending on the technique and the number of parameters tested, automated test cycle times can be comparable with "Listeners."

1.5 With the advent of high speed DSP technology, the prospect of integrating positive aspects of both techniques is possible. Tests can be configured to more closely emulate the elements of hearing which make "Listener" based testing attractive and complex signal generation and FFT analysis provide the technical basis to perform highly sophisticated automated tests within required cycle times.

2. WHAT KIND OF LOUDSPEAKERS?

2.1 A survey of loudspeaker designs would include electrostatic, dynamic-direct radiator, piezoelectric, compression driver/horn, electromagnetic, ion and airflow types. Several of these are considered esoteric, while others have enjoyed varying degrees of critical and commercial acceptance. Among these, the dynamic-direct radiator and compression driver/horn types are, by several orders of magnitude, the two most common in use. It is these two which are the subject of this work.

3. WHAT GOES WRONG?

3.1 Loudspeakers can be generally viewed upon as functioning in three basic areas or three circuit types: electrical, mechanical and acoustical. Figure 1 shows side-by-side, a typical direct radiator loudspeaker and compression driver, with these circuits represented. As one would anticipate, problems can arise in any one of these areas. However, in practice, since the electrical part of the loudspeaker system is a "simple" electromagnetic coil interfaced to a power amplifier and its performance is generally predictable, it is possible to "design out" most of these potential problems. Similarly, the acoustical part of the loudspeaker is comprised of the "simple" interaction between the cone/diaphragm and atmosphere, and with the exception of "air" or "throat" distortion found in compression drivers, provides the smallest contribution to the degradation of quality in the loudspeaker itself. With this in mind, it can be seen that the greatest majority of anomalies that occur within a loudspeaker are mechanical in origin.

3.2 Mechanical in this context, is defined as having anything to do with the superstructure (basket, motor structure, cabinet, hardware, etc.), stationary or moving physical components and foreign bodies. For example, if the voice coil has shorted in the gap, although this presents an electrical problem, it is a mechanical anomaly. Likewise, if a compression driver's phase plug is defective or improperly placed, although this increases air/throat (acoustical) distortion, it too, originates as a mechanical anomaly.

3.3 A distinction should be made between the mechanical anomalies called "Rubs" and "Buzzes" and another set of descriptives, "Chips" and "Rattles." The former are directly associated with the movement of the voice coil, spider (voice coil suspension), diaphragm, cabinet resonances, etc. and are frequency dependent, typified by an edgy, unpleasant sound that shifts spectra with relationship to the stimulating frequency. The latter are associated with the presence of foreign particles in the loudspeaker, loose fasteners, improperly mounted crossovers, etc.. Although they too are energized by the dominant movement of the loudspeaker, they can exhibit qualities of frequency independence as much as dependence. In addition to their deep buzzy character, they also exhibit a quasi-random, sometimes wideband noise which can be difficult to quantify. For our purposes, the distinction between these different types of anomalies will only be made as warranted by specific examples. Otherwise, all such anomalies are referred to herein as **Loudspeaker Mechanical Anomalies (LMAs)**.

3.4 As can be expected, LMAs occur from a wide variety of defects. Categorically, some common causes are listed below.

1. Rubs:
 - a. Offset pole plate
 - b. Offset magnet
 - c. Adhesive in air gap
 - d. Out of round voice coil
 - e. Cocked spider (voice coil suspension) on voice coil blank

- f. Cocked cone on voice coil assembly
- g. Short pigtail leads pulling on cone body
- h. Excessive amounts of adhesive on cone surround
- i. The basket may be bent or misshapen

2. Buzzes:

- a. Loose or insecurely glued screen
- b. Improper adhesive placement at pad ring to cone joint
- c. Improper adhesive placement at cone to basket joint
- d. Cone surround coming loose from cone body
- e. Pigtail leads touching cone body
- f. Internal wires touching
- g. Adhesive void around cone to coil joint
- h. Adhesive void around dust cap or whizzer
- i. Loose windings on voice coil
- j. Loose collar on voice coil blank
- k. Adhesive void between the basket and the front plate
- l. Small tears or holes in the cone, spider or surround
- m. The cone or diaphragm may experience oscillation modes at certain frequencies when excited
- n. Improper seating of phase plug resulting in irregularities in acoustical loading resulting in increased distortion
- o. Compression driver diaphragm may make contact with the phase plug

3. Chips:

- a. Bad plating on front plate
- b. Improper positioning of magnet to pole plate
- c. Production line vacuums not operating properly or dirty, leaving particles in the gap

4. Rattles:

- a. Congenital mechanical defects
- b. Loose or improperly secured fasteners, hardware, accessories
- c. Foreign particles may get caught up in the spider or cone
- d. Improper mounting or torquing of the basket (in fixture/cabinet)
- e. Improper design, construction or assembly of fixture/cabinet

3.5 Other inherent non-linear distortions which contribute to the composite signal include:

- a. Driving force distortion, caused by variances in the magnet-to-voice coil circuit as the voice coil moves in and out of the magnetic field gap, increasing as the motor assembly approaches and moves through X_{max} , (For an interesting approach to X_{max} measurements, see Clark.)⁹
- b. Air distortions (throat distortion) in compression drivers, is a by-product of the mechanical to acoustical transfer function of the loudspeaker resulting from the acoustical impedance mismatch of air and cone,¹⁵
- c. Doppler/FM distortion, which results from the modulation of any upper frequency by a lower frequency simultaneously stimulating a loudspeaker, thus generating FM sidebands.² (see Sec 6.9)

3.6 These distortions can contribute negatively to the "perfect" linear performance of a loudspeaker. Engineering improvements have, in many cases, reduced them to inaudible levels. What we must recognize is that although low level, they are still measurable and exist in good and defective loudspeakers. Thus, the potential exists that they may become an additional variable when measuring **LMAs**.

4. ON EVALUATION TECHNIQUES

4.1 The techniques of automated frequency response, polarity, sensitivity, phase and impedance testing of loudspeakers in production through the use of pass/fail limits created by referencing to test results of known good or "golden" units has become an accepted convention. Even automated Thiele-Small signal parameter measurements are becoming part of the accepted way loudspeakers are tested.⁵ It has been harder to achieve reliable results from applying this "transfer standard" technique for LMA testing. This is one of the reasons that "Listeners" are still frequently used as "human test instruments."

4.2 To be fair, the human hearing mechanism has had several millennia to develop and perfect itself and as such, is much further along the R&D pipeline than our electro-mechanical cousins. Also important to recognize is that the obstacles which automated analyzers encounter in production environments, and must overcome in order to successfully judge the quality of loudspeakers, are quite real.

4.3 These include:

- a. Limitation of the test time due to the rate of production
- b. Noisy testing environments
- c. Acoustic effects of test fixtures including echos, resonances, nulls and nodes
- d. Electrical interference and induced distortion from power amps, AC line and RF sources
- e. Variances in loudspeaker sensitivity (moving target)
- f. Acquisition and processing limitations of test instruments to reliably and repeatedly "hear" or quantify various LMAs

4.4 Because human hearing is fairly immune to these conditions and can adapt to changes in environment, a large majority of testing is still performed by "Listeners."

5. ON TESTING - "LISTENER" CONVENTIONS

5.1 Over time, the hearing mechanism has evolved into what might be described as a sophisticated spectrum analyzer with data processing power like that of today's high speed parallel processors, constantly evaluating an incoming signal at all points within its dynamic and spectral operating range. Aural perception begins (Figure 2) with a sound being filtered across the pinna (outer ear) and routed through the ear canal to the eardrum. Once a signal has passed through the ear's acoustical-mechanical-electrical converter and has been broken down into its constituent components, this data is then dispatched via the auditory (8th) nerve to the auditory center of the brain, where highly selective frequency, amplitude and timebase filtering, processing and analysis is accomplished.

5.2 A vast body of research has been amassed in the study of the physical side of the hearing process. Of recent note is a study by Breithaupt, which employs the relatively new technique of In-The-Ear[®] microphone placement for the examination of variances in listener perception.³ These ITE experiments have provided some very realistic models and furthered the understanding of the ear's response, directionality, and sensitivity characteristics as well as helping to isolate physiological reasons for differences in listener-to-listener perceptions of sound.

5.3 On the other hand, since much of the ability and degree to which a listener processes this data is internalized in the brain, and is a function of its built-in "software," we have yet to determine the precise nature or mechanics of these processes. Though much is known about the physical and functional makeup of the

outer, middle and inner ear, our knowledge of the actual processing methods by which these functions are accomplished is based primarily on observation and interpretation of listener interviews and is in and of itself, the subject of much research and debate.

5.4 Part of this "software" that allows us to make comparisons, cross correlations and quality judgements is dynamic and varies with a person's experiences and degree of aural sophistication.¹⁸ It is this dynamic aspect of human hearing which lends support to the general belief that a trained "Listener" will fare better than conventional test instrument in the identification of **LMAs**. In theory, it provides for an infinite set of "limit files" to be mentally created, allowing for variances that would conform to the acceptable standard deviation in a particular product. Obviously, retooling and reprogramming time is insignificant, and then there's that famous gut feeling "algorithm" which makes it possible to determine acceptance of good units "hovering about" the limits of pass/fail requirements.

5.5 Given all this, why do we even bother to try and come up with a test method using hardware and computers? Maybe we should just give all these wonderful "Listeners" a raise, shorter shifts, and a soft pillow.

5.6 However impressive the psychoacoustics of human hearing, there are some practical limitations in the use of subjective "Listeners" employed as production line testers. General categories of concern are test accuracy and repeatability, standardization, physical limitations of "Listeners" and health hazards. Specific points of concern are listed below.

- a. Subjective quality assessments provide no tangible standards
- b. Because of individual differences in perception, "Listeners" develop their own pass/fail criteria
- c. "Listeners" must learn how a good loudspeaker should "sound" based on timbral characteristics and make this their mental reference
- d. A "Listener's" effective frequency and dynamic hearing range will vary with time and exposure
- e. The degree to which a "Listener" can subjectively discern good units from bad is affected by their level of experience.
- f. Since the "auditory memory" typically holds absolute information for a matter of milliseconds, "Listeners" cannot make direct A/B comparisons with known good units.
- g. Precise physical positioning of the "Listener" with respect to the loudspeaker can be critical
- h. Since a "Listener" updates his mental limits, in part, from the acceptable units he is testing, gradual increases in the number of marginally acceptable units produced and examined may cause increased leniency
- i. Headaches, colds, allergies and other physiological anomalies that alter normal operation of the "Listener's" hearing "instrument" subsequently degrade the quality of their Q.C. assessments.
- j. Changes in the "Listener's" general and daily physical, mental and emotional state are inseparable variables in their Q.C. decisions
- k. Physical and neurological "Listener" fatigue result from repeated exposure, creating conditions of temporary hearing loss including notches, rolloffs, comb filtering and general desensitization
- l. Exposure to high SPL signals and long-term repeated exposure to some mid SPL signals is proven to cause permanent hearing loss in individuals

5.7 For these and other reasons, it is common to see pass/fail limits "wander"

from start to finish on any given "Listener's" shift and even more dramatically, from shift to shift. So, even with the best "Listener" on the best morning of his best day, the standard will "wander." Additionally, on the practical side, the costs associated with maintaining this specialized labor force may be undesirable or these workers might in fact be of greater benefit in some other capacity.

6. ON TESTING - EQUIPMENT CONVENTIONS

6.1 In an effort to replace "Listeners" for LMA testing, several techniques have been devised using audio analysis equipment, with varying degrees of success. Some of these include a swept fundamental with an auto-tracking bandreject filter for THD+N (Figure 3), swept fundamental with an auto-tracking highpass (Figure 4) or bandpass (Figure 5) filter, parked fundamental with swept highpass (Figure 6) or bandpass (Figure 7) filters and swept fundamental with parked highpass (Figure 8) or bandpass (Figure 9) filters. These methods are based on the idea that LMAs can be identified by amplitude detection at a particular harmonic or harmonic range. The harmonic placement of these filters is typically determined through feedback from "Listeners." This usually places them above the fourth harmonic.

6.2 While these methods have been able to detect varying degrees of LMAs, they have some difficulty with low level and frequency independent LMAs. These account for a substantial number of failure rejections when testing is performed by a "Listener." So, it is still common for some loudspeaker manufacturers to "double-up" or substitute test instruments with a "Listener" for LMA tests.¹¹

6.3 If we compare the above techniques with our basic understanding of how the hearing mechanism works, we can submit that some possible reasons for these differences in performance may be due to:

- a. The types of filtering used in qualifying incoming signal for analysis including highpass filters and bandpass filters with too low a "Q"
- b. Filter frequency accuracy
- c. Filter tracking method used to follow particular harmonics
- d. Inflexibility due to limited choices of harmonic filters
- e. Methods of stimulus
- f. Insufficient time to allow for proper settling before measurement and importantly,
- g. The inability to simultaneously and discretely analyze a complex array of frequency/amplitude components, as in the case of the ear

6.4 The following comparison attempts to illustrate the character, effect and limitation of the use of bandpass type filters. Keep in mind that these are best-case examples, where the center of the filters have been precisely (manually) placed. For typical production testing where sweeping of the fundamental is required, this degree of precision is unlikely. Shown are FFTs of the spectra of a good compression driver stimulated with a sinewave at 445 Hz while attempting to isolate the 7th harmonic with a: 1/3 octave bandpass filter (Figure 10), 1/8 octave bandpass filter (Figure 12) and 1/10 octave bandpass filter (Figure 14). Figures 11, 13 and 15 parallel the above examples, only in these FFTs, the spectra is of a defective compression driver with harmonic evidence of an LMA at the 7th harmonic.

6.5 Looking at both series of figures, as we progress from the first to the third example, note that there is a gradual improvement in frequency isolation as we tighten the "Q" of the filter. However, even when employing a very good 1/10th octave digital bandpass filter* (Figures 14 & 15), there is still a significant contribution of energy "leaking" into the bandpass from the surrounding

constituents. Even though the individual amplitude of the 7th harmonic is greater in the "buzzy" unit, the total level of energy within the bandpass on the good unit is equal or greater, making it difficult to obtain a reliable assessment.

6.6 Another difficulty encountered by test instruments in detecting LMAs is that quite often, the amplitude of the primary frequency of the anomaly (the "buzz") falls at an amplitude below the reasonable upper limit set for pass/fail. In fact, sometimes the amplitude of the primary frequency of the LMA falls even lower than the amplitude of the harmonic normally expected at that frequency in the good "golden" unit. In this case, detection is all but impossible for single bandpass analyzers. (see Sec 9.17)

6.7 Problems may arise if the sensitivity of the LUT is lower than the reference unit, yet within desired limits. When measurements are made in absolute units, this will cause the entire curve to fall artificially low and increase the likelihood that defects will be overlooked. Similarly, if the sensitivity is a bit higher than the reference unit, a good unit may fail.

6.8 This example holds true for swept generator/tracking bandpass tests using this technique, as well. The potential for analysis is diluted even further when highpass filtering is employed. Although this does examine a larger area of the harmonic spectra and will sense considerable increases in spectral energy, it in effect, presents the analyzer's pass/fail comparator with a numeric value of all the energy above the highpass frequency, allowing for little qualification of or discernment between contributing components.

6.9 Another infrequently discussed area that can cause problems in accurate LMA analysis is the power source/amplifier. The individual harmonic distortion components of a loudspeaker can be quite low (-40 dBr to -70 dBr ref. to fundamental). If the amplifier has a significant degree of AC hum, these components, depending on their relative phase to the stimulus, can sum or null. This causes levels to fluctuate and can prevent the analyzer from settling properly. AC hum can also cause frequency instability due to intermodulation with, and Doppler/FM modulation² of the stimulus and its harmonics. To illustrate, **Figure 16** is an FFT of the measured output of a loudspeaker with a 1 kHz tone. The amplifier is well grounded and in good condition. Note the AC contributions. Below in **Figure 17** is an expanded view of the same FFT around 1 kHz. For convenience, the horizontal scale is in "Delta Hz", in 60 Hz divisions. We see that even with a good amp, FM sidebands are present, albeit at -88 dB below the fundamental. The FFT in **Figure 18** now shows the effect of a larger 60 Hz component. Note the "spreading out" effect on not only the fundamental but the harmonics as well. In the higher harmonics, this causes energy to spread out and fill in the areas between the harmonics. **Figure 19** shows the expanded view of this FFT around 1 kHz with the more dramatic FM sidebands.

6.10 Less of a problem is non-power supply related amplifier noise and distortion. When operating properly, the noise floor on most amplifiers is at best, below the threshold of hearing, and at least, masked from hearing by the presence of program signal. However, since these artifacts can be measured and are being routed to the loudspeaker, they become part of the composite signal being analyzed. Therefore, if relatively low levels are to be analyzed, the possibility exists that any instability in these contributions may interfere with the measurement. The risk of this increases with progressive component failures in the amplifier. Also, drive levels from the test generator to the amplifier should be carefully controlled to avoid clipping of the input stage.

6.11 If a microphone pre-amplifier is to be used in the test signal path, the same precautions should be observed. In general, testing of one's test equipment on a

regular cycle is recommended, and a good in-house maintenance and calibration program will in and of itself, contribute greatly to the reliability and repeatability of measurements.

6.12 Upon reviewing the various LMA detection techniques in this section, it can be fairly stated that, although evidence of the anomalies is acquired by the measurement microphone and presented to the analyzer, it is difficult for the filtering section of the analyzer to adequately separate them for discrete analysis. Thus, when a "Listener" hears undesirable distortion products, they can be hidden from these types of analysis by a kind of "filter induced masking" which relates back to the "Q" of the filter and the monotonic (one-frequency-at-a-time) nature of these types of analyses. As we see in looking back at Figure 15, even when the measurement filter has a high "Q", it is still difficult to detect discrete signals due to adjacent harmonics, non-harmonic components and noise. Tighter limits can allow for greater failure rejection but will frequently cause good speakers to begin failing as well.

7. ON TESTING - ALTERNATIVES

7.1 Because of the distinct way that each processes the acquired data, LMA testing results from conventional test instruments don't always correlate with those via a "Listener." Since "Listener" based LMA testing is frequently used for loudspeaker evaluation, confirmation of ATE results and for defining known good or "golden" references, something should be gained through a better understanding of what the "Listener" is hearing. As discussed in Sec. 5, much of what is known about hearing is still subjective. We recognize that the ongoing compilation of these subjective analyses form the foundation of present methods of LMA detection. Ergo, implementation of this knowledge should help provide a basis for developing techniques that more closely parallel the positive aspects of the "Listener's" inherent hearing ability.

7.2 Our technology has now achieved a level of sophistication where we may begin to effectively emulate the analysis capabilities of human hearing. While processes such as Fast Fourier Transform (FFT), digital waveform analysis, digital filtering and high level digital signal processing (DSP) have afforded us significant technical advances, they simply provide a set of tools with which we can engineer test methods to achieve desired results. The balance of the challenge is then to learn how to incorporate the key advantages of these tools (hardware & firmware) with what we know about the nature of hearing (software & "liveware") into an effective integrated test and analysis system/ measurement technique. As we increase and improve upon our implementation of this knowledge, evidence of greater correlation of the results should be seen between methods.

8. EXPERIMENT 1: EVALUATION OF HUMAN HEARING CHARACTERISTICS FOR USE IN LMA TESTING, THROUGH LISTENING TEST & FFT ANALYSIS OF A FLUTE, OBOE & LOUDSPEAKERS

8.1 Before attempting to integrate psychoacoustic aspects of hearing into LMA testing, these aspects need to be prioritized with regard to their function in making positive LMA detection. Elements to consider are:

- a. Identification of unique spectral signature, or the ear's ability to "pick out" and identify the origin of certain spectral patterns, while in the presence of a more dominant signal from another origin.
- b. Auditory weighting and sensitivity curves which affect perceived levels
- c. Induced frequency masking of adjacent and harmonic frequencies
- d. The ability to extrapolate "unheard" frequencies from those heard

8.2 Defining the target, the hypothesis is that most LMAs are, in fact, band limited squarewaves imbedded within the spectra/waveform of a more dominant fundamental. Because a loudspeaker is itself "an acoustic instrument," a series of comparisons to equate performance to "traditional" acoustic instruments are given. By using a Flute and an Oboe for signal generators, parallel evaluations can be made without concern for contributing factors from any recording, reproduction or other loudspeaker system. These instruments were selected because of their known parallel with the spectral characteristics of sinewaves and squarewaves and provide a useful "control" on which to base this study.

8.3 To illustrate the hypothesis, a simultaneous listening test, reference FFT and corresponding waveform analysis was made on each of the following at a frequency of approximately 394 Hz (Concert G): solo Flute (Figure 20-21), solo Oboe (Figure 24-25), good LUT with sinewave (Figure 22-23), good LUT with squarewave (Figure 26-27) and a "buzzy" LUT with sinewave (Figure 28-29).

8.4 As proposed, the "smooth" or "round" sound of the Flute in Figure 20 compared well with the good LUT w/sinewave in Figure 22. Similarly, the Oboe's "rich" or "edgy" sound, was like the sound of the good LUT w/squarewave and the "buzzy" LUT w/sinewave. A comparison of the FFTs in Figures 24, 26 and 28 indicate that the increase in timbral "richness" of each, is due to the increase in spectral density, upper and odd order harmonics. Likewise, comparing the respective waveforms in Figures 25, 27 and 29 show the similarity they all share with a band limited squarewave by their faster rise times and distribution of high order harmonic content. These similarities in timbre, spectra and waveform have their origin in the manner each generates signal.

8.5 In unison with the Flute (Figure 30), but at a level down better than 5:1, we can still hear the spectral components or timbre of the Oboe. Figure 31 shows the Delta of the combined FFT, that is to say, less the Flute's contribution. This situation might be equated with what happens when a "Listener" detects a slight evidence of an LMA. Further reducing the Oboe's level to less than 6:1 (Figure 32) the Oboe audibly "disappears" from hearing under the Flute. The Oboe's spectra is so suppressed that it is even difficult to see in the FFT. However, in Figure 33 we can see that Delta contributions of 10 to 20 dB are still present at certain harmonics. The fact that the ear fails to discriminate, while the FFT continues to detect these components is important. This means it is possible to filter out loudspeakers with a predisposition toward LMAs, prior to their becoming audible.

8.6 This difference in discrimination can be attributed to effects of the natural weighted hearing curve (Figure 36)^{10,14}, and the effect of frequency masking (Figure 37). Primary study of this phenomenon has been in noise perception for developing noise reduction systems,^{7,8} hearing aids, and most recently the need for data compression of digital audio. Development of bit reduction schemes in Dolby's AC-2[®] and Phillips' DCC[®] have helped evolve a better level of understanding in this area. Masking is a form of built-in noise reduction- distortion suppression that the ear employs to reject certain frequencies within a critical bandwidth of a strong signal.^{17,19} It is this induced insensitivity to relatively high levels of low order (2-5) harmonic distortion, that allow "Listeners" performing loudspeaker testing to appear to ignore relative increases in these harmonics.¹⁷

8.7 Because the "contour" of the ear's sensitivity varies with different SPL levels,^{10,14} an entire series of filters would be needed to be fully representative. Rather, "compromise" filters, have been created which ostensibly represent a "typical" hearing curve. Three weighting filters commonly used to emulate these hearing characteristics in audio analyses are "A" weighting, CCIR and CCIR-ARM. Figures 34 and 35 show an overlay of these curves along with the

inverted and normalized ISO curves at 90 dB SPL and 10 dB SPL, respectively. Comparing these graphs, we see that these filters are optimized for low level and noise measurements, and that the differences in response become greater with higher SPL levels, especially in the frequencies below 1 kHz. Since levels of 90 dB SPL or greater are common for "Listener" based LMA testing, this presents a problem to our LMA analyzer model. If we adopt any of these filter schemes for pre-qualification of signal, the net signal we analyze will deviate from hearing by as much as 15 or 20 dB in the very spectral region where most LMAs originate.

8.8 Rather than using pre-acquisition filters, another approach to providing appropriate weighting and masking referencing utilizes Delta computations of the acquired signal. **Figure 36** shows the ISO curve for 90 dB SPL "normalized" to 0 dB at 1kHz. Normalizing provides the basis for proper Delta computation of subsequent data (positive numbers subtract, negative numbers add). **Figure 37** shows the response curve of the ear's aural masking characteristic at 90 dB SPL, for a 445 Hz signal. **Figure 38** is the pre-Delta FFT of a good compression driver at 90 dB SPL/445 Hz and **Figure 39** is the pre-Delta FFT of a compression driver with a high frequency "buzz," again at 90 dB SPL/445 Hz.

8.9 By subtracting the 90 dB SPL ISO curve from the FFTs, the amplitudes of the FFTs are adjusted (Delta) so that they correlate with the ear's relative perception of these frequencies. So, we are able to get an "ISO weighted" curve for this SPL level, in post-processing, that yields a more realistic representation of the ear's response characteristics. The subsequent Delta FFTs in **Figure 40** and **Figure 41** show the good compression driver and the one with the high frequency "buzz," respectively.

8.10 To demonstrate the effect of aural masking on perception, we overlay each of the FFTs with the masking curve from **Figure 37**. **Figure 42** is the good unit, **Figure 43** the high frequency "buzz." Note that masking effects of the fundamental are felt through the eighth harmonic. This masking "line" represents the dynamic "threshold" of hearing in the presence of signal. For example, the third harmonic at 1335 Hz in **Figure 42** will not necessarily be perceived at its absolute level of 60 dB SPL, but rather at 10 dB above the ear's threshold. As we move higher in harmonics, frequency/amplitude perceptions are less affected by masking effects of the fundamental.

8.11 However, what is postulated here, is that additional masking curves will form around the stronger mid-harmonics, thereby providing a degree of high frequency masking. For example, **Figure 44** (good unit) incorporates the fundamental mask per **Figure 42**, but we have added a second mask centered at the fourth harmonic. The fourth was selected for this example since it had the greatest amplitude difference above the fundamental's mask. Note the degree of upper masking. We repeated the process on the "buzz" unit in **Figure 45**. This time, note that in addition to the richer high order harmonics, the amplitude of the fourth harmonic is lower. So, not only does the unit have a high frequency "buzz," but the constituent that provided the upper harmonic mask, has been attenuated, making its mask less effective and the "buzz" more obvious.

8.12 Additionally, the hearing mechanism possesses the ability to psycho-acoustically extrapolate frequencies.^{9,16} This is important to recognize because quite often the filters and harmonics that we choose to test are selected based on the results of subjective listening tests. For example, if the 3rd, 5th and 7th of a chord are played without the fundamental or "root" of the chord, the hearing mechanism can mentally "create" it. So, if our hearing indicates to us that an LMA is occurring at frequency x, it may well be the result of psychoacoustic extrapolation and actually be occurring at frequency 2x, 3x, 4x, etc.. or conversely, at 1/2x, 1/3x, 1/4x, etc. Therefore, what we think we hear may not be

at all what we hear. This suggests that if we select the number or range of harmonic frequencies to analyze based on absolute, uninterpreted reports from "Listeners," the possibility that we may miss our target increases.

8.13 Based on prior knowledge^{7, 8, 9, 10, 14, 17, 18} and this experiment, the following conclusions may be submitted to help build our model **LMA** analyzer:

- a. The ear has the ability to simultaneously monitor and analyze a vast number of frequency/amplitude constituents (complex waveforms) within its operating range.
- b. The ear's ability to perform these analyses is affected and limited by the effects of aural masking.
- c. As a result of masking low order harmonics are typically inaudible or perceived as unimportant by the ear.
- d. The ear has a spectral weighting system which causes it to emphasize certain frequencies while de-emphasising others.
- e. The (educated) ear can identify various spectral combinations or timbres, and relate them to mentally stored impressions.
- f. The ear can extrapolate "un-heard" or phantom frequencies from those it does hear.

8.14 From this we can derive a technical simile to form the basis of our model:
"The ear's performance is like a weighted acquisition, constant bandwidth FFT with level dependent, selective band frequency masking characteristics, and whose input stage autoranges to incoming levels so as to provide a dBr (dB relative) response analysis referenced to the most significant constituent frequency in any particular critical band."

8.15 Furthermore, with respect to **LMAs** themselves it may be stated that:
"Because of the "binary" nature of their origin, frequency dependent **LMAs** exhibit spectral characteristics similar to squarewaves, with odd order harmonic energy extending upward in frequency to an extent modified and limited by the frequency response characteristics (high frequency rolloff) of the loudspeaker, the frequency at which the **LMA** begins and the amount of fundamental energy transferred to the **LMA**."

9. EXPERIMENT 2: SINGLE TONE STIMULUS & FFT ANALYSIS OF LMA

9.1 In order to isolate evidence of low level **LMAs** for detection, we need to employ techniques similar to those used in the isolation of the low level Oboe signal (Sec. 8). While it would be useful to predict actual causes of **LMAs**, we must first be certain that we have established a reliable method of **LMA** identification and establish criteria for Maximum Fault Acceptability (MFA). In light of this, the ear's ability to differentiate between waveforms and unique harmonic spectra (timbre) and extrapolate unheard or "phantom" frequencies from related frequencies (harmonics) provides an important perspective in the development of our model **LMA** analyzer.

9.2 Since **LMAs** cause the loudspeaker to exhibit an elevated degree of upper and odd order harmonics (Sec. 8.13-8.15), their waveforms and spectra begin to take on characteristics of a squarewave. **LMAs** vibrate sympathetically and become active when they are stimulated by harmonically related frequencies. The strongest **LMA** vibrations will occur when the stimulus is at any one of the octaves below its starting frequency. However, **LMAs** will also become active, in varying degrees, when stimulated by "familial" frequencies such as fifths, fourths, thirds, etc., much like the strings on a piano. There is no rule in predicting the frequencies where **LMAs** will occur and the **LMA** can occur anywhere from the stimulus frequency

(f_0) to any number of octaves above. It should be noted that although **LMAs** can occasionally occur as sub-harmonics, they typically occur in the range above a given stimulus.¹⁶

9.3 In this experiment, we perform two comparisons between FFTs of a good reference LUT and those from the same LUT with induced **LMAs**. The **LMA** induced in the first comparison is gross, while the second is hardly audible.

9.4 The known good LUT is a $4\frac{1}{2}$ " general purpose driver designed for 15 kHz bandwidth operation with a resonance frequency of approximately 110 Hz and nominal impedance of 8 Ohms, driven with 80 Hz at 5 Volts, supplying an approximate acoustical output of 100 dB SPL to the microphone at 4". Test setup conforms to the setup in **Appendix 2: A2.1 - A2.2** and the diagrams in **Figures 97 and 98**. The graphs are frequency/amplitude "normalized." The horizontal scaling is in F/R (frequency relative) units referenced to the 80 Hz fundamental, so that the divisions 1 to 31 refer directly to harmonics 1-31 (eg. 2 = 160 Hz... 31 = 2480 Hz). The vertical scale is in dBr (dB relative) units, referenced to the measured amplitude of the fundamental. The dBr scale is re-referenced for each example so that all amplitudes are expressed in (-)dB below the fundamental. This dBr scaling is rather important, as discussed in **Sec. 6.7**, and parallels the way that the ear references to a dominant frequency.

9.5 To provide as detailed an Acoustical Profile of the good reference LUT as possible, four sub-profiles are submitted as follows:

- a. **Figure 46** shows an FFT of the LUT's frequency/amplitude components, referenced as described above.
- b. To ascertain the typical range of test-to-test deviation for this environment and loudspeaker type, the LUT was re-tested and the data from **Figure 46** subtracted from the new acquisition, leaving the Delta (or difference) of the two in **Figure 47**.
- c. The stored FFT data from **Figure 46** was then re-processed and re-displayed in the time-domain, yielding the waveform analysis in **Figure 48**.
- d. The test was repeated, only this time, rather than supplying the FFT analyzer with a wide band amplitude source, the system's THD+N notch filter was inserted into the signal path, removing the fundamental and yielding the remaining THD+N waveform in **Figure 49**.

(This same procedure was followed for each of the two subsequent cases of induced **LMA**. Their corresponding Acoustical Profiles for these LUTs follow immediately after the reference set listed above.)

9.6 In **Figure 46**, it can be seen that a pure sinewave played through a known good LUT exhibits a natural harmonic spectra, with regularly diminishing amplitudes as we approach the higher order harmonics. Note that this known "good" LUT seems to have a slight "buzz" of its own, becoming fairly noticeable at around $f_{1.5}$ and continuing through $f_{2.6}$ before returning to the prior trend of diminishing amplitude vs. increased harmonic number. The fact that the noise floor of the FFT also rises and falls significantly within this region allows us to extrapolate that there are both frequency dependent and frequency independent **LMAs** present. All the better that our reference has some imperfections. Since it sounded fine to the ear, its a good example of the type loudspeaker that a listener would approve in production and might well have become someone's "golden" standard. (Perhaps that's why we refer to them as "known good" and not "known great"...)

9.7 The examples in **Figures 50-53** depict the Acoustical Profile of an extreme case, where we induced a rather robust **LMA** by exerting trans-axial pressure on the

back of the cone, causing the voice coil to come in contact with and "rub" against the sides (walls) of the gap. For added effect, cellophane was placed between the cone and basket.

9.8 Comparing the FFT in Figure 50 with our good reference in Figure 46 along with the Delta FFTs in Figures 47 and 51, it can easily be seen that there is a shift in the upper spectral content as well as an increased emphasis in odd order harmonics. This is how a severe Frequency Dependent LMA is supposed to look.

9.9 What is important to reinforce here, is that from a practical and analytical perspective, the source of the LMA becomes its own "fundamental" with a unique harmonic family, whose Periodic Harmonic Interval (PHI) is a multiple of the fundamental's, and whose harmonics exhibit noticeable squarewave characteristics. Since this LMA source is really a harmonic "offspring" of the "parent" fundamental, and not a true fundamental, we refer to this phenomena as a Secondary Harmonic Source (SHS).

9.10 Harmonic frequencies may be expressed in terms of their Secondary Harmonic Source:

Where:

n = the harmonic number of the true fundamental and

x = the harmonic number of the SHS

$$\text{SHS}(s_n)_x \text{ (or) } \$(s_n)_x$$

For example, an SHS at 300 Hz with a fundamental of 100 Hz could be expressed

$$\$(s_3)_1$$

Likewise, the third harmonic (900 Hz) of this SHS could be expressed

$$\$(s_3)_3$$

so,

$$\$(s_3)_3 = s_{900}$$

9.11 Using the technique established in Sec. 8 whereby we determined that the ear can extrapolate fundamental frequencies from higher harmonics, we derive that the SHS is located at s_3 . We know this because when we examine the FFT, we see a series of dominant amplitudes occurring at s_{11} , s_{15} , s_{19} , and s_{23} and form an equally spaced pattern whose PHI is 4 Fundamental Units (4FU) wide. So, if we apply our theorem that an LMA is a band-limited squarewave imbedded within the spectra of the fundamental, and we accept that the aforementioned harmonics are in fact the odd order constituents of that wave, then the lower amplitude constituents of s_3 , s_{13} , s_{17} , and s_{21} must be the even order harmonics. Subtracting any one of these harmonic numbers from the next highest (eg. s_{21} & s_{23}) leaves a difference of 2 Fundamental Units (2FU). Finally, adding 2FU with 1FU (for the true fundamental) produces a sum of 3FU. So, the SHS should be at s_3 or $\$(s_3)_1$ and since $f = 80$ Hz, then $\$(s_3)_1 = 240$ Hz. Upon closer examination of the FFT in Figure 50, we can see the amplitude of s_3 (the third harmonic) is in fact, approximately 6 dB greater than its counterpart in the good example in Figure 46, and is in all likelihood, an SHS.

9.12 Plainly, in addition to the SHS at 240 Hz and its family, there are other contributions as well. For one, the s_3 is suppressed by better than 18 dB, lending suspicion that the fundamental itself has a pretty good squarewave component rooted there. By repeating the above process, other SHSs can also be defined.

9.13 For additional proof of the presence of a squarewave, we turn our attention to the waveforms below the FFTs. If we first compare the complete waveforms in Figures 48 and 52, we see a decrease in peak-to-peak amplitude of 7.9 mV in the LMA example, and a slight high frequency "fringing" of the trace in the LMA waveform. At first this change in waveform topography may appear small as compared with the dramatic rise in upper harmonic spectral energy in the FFT. Keep in mind though, that the change in relative amplitudes of the two most prominent harmonics was contrary. f_3 , increased by 6 dB or 19.75%, while f_2 had a relative loss of 18 dB or 48.39%.

9.14 So, where did the 7.9 mV loss in fundamental energy go? Figure 53 shows the fundamental removed via the THD+N notch filter. We see not only a dramatic rise in peak-to-peak voltage, but a significant squarewave(s). Subtracting the 3 mVpp in Figure 49 from the 7.8 mVpp in Figure 53 yields a net increase of 4.8 mVpp or 160%. That still leaves unaccounted 3.1 mVpp of lost fundamental energy.

9.15 First, further examination of Figure 53 reveals a large amount of undefined high frequency energy within the waveform. If we were to subtract the RSS (root-sum-square) of all the non-fundamental components (eg. $f_2 + f_3 + f_n \dots$), in Figure 49 from the same in Figure 53, this would probably represent most of the amplitude loss from the fundamental. Then of course, the added acoustical impedance from physically restricting diaphragm movement would cause some energy to be converted into heat. Last, a small but measurable amount of non-fundamental energy may have been removed from the acquisition via the "skirts" of the THD+N filter.

9.16 So, given the example expressed in Figures 50-53, it can be seen that in extreme cases, LMA detection and SHS projection are fairly straightforward.

9.17 Now let us turn our attention to Figures 54-57 where care was taken to induce an LMA whose amplitude is extremely low. In this case, a small piece of cellophane was held against the cone, and pressure gradually decreased until the desired low-level LMA was achieved. Comparing the full band FFT in Figure 54 with the good reference in Figure 46, we see little obvious differences. Likewise, when comparing the waveform analyses in Figures 56-57 with Figures 48-49, change is not obvious. This is because the most pronounced increases in amplitudes are occurring at higher frequencies. In order to make an adequate comparison, we need to examine the Delta FFTs. In Figure 55, we see that all harmonics below f_{11} are within the levels of acceptable deviation established in the Delta FFT in Figure 47. It is only above f_{11} that we see increases in the amplitudes of specific harmonics. Interestingly though, examining the Delta in Figure 55 for this induced LMA, we see that several of the low order harmonics (f_{2-7}) have lower amplitudes than their counterparts Figure 47.

9.18 This effect, allows us to postulate that these decreases are evidence of the beginnings of the "squaring" of the waveform. This point is reinforced by the fact that these differences have the same trend of gradually increasing amplitudes that have been demonstrated in Delta FFTs of other LMAs. This evidence suggests that in the early stages of an LMA, energy may first be removed from these low order harmonics and transferred to the higher harmonic order before increases in low and mid order harmonics occur. This means that rather than solely detecting an LMA through increased levels in harmonics, detection may also be achieved by monitoring decreases in harmonics, with a net result being the same.

9.19 Continuing with Figure 55, if we now examine the harmonic region above f_{11} , we see that in addition to the half dozen or so components that are significantly elevated in level there is a strange "reversal" in the amplitude trend from f_{17} through f_{25} , before it returns to the expected LMA trend of increasing amplitude vs. increased harmonic number. This is because, if we recall from Sec. 9.6, our good

reference example has low level **LMAs** in this region, and the induced low level **LMA** fails to mask it, as did the previous high level example. So, the reversal in spectral intensity is the interplay between these **LMAs**.

9.20 In spite of this interference, we are still able to detect some specific Delta deviation. As in the previous example, there is once again a pattern forming. For example, f_{12} , f_{18} and f_{24} have a **PHI** of 6SU . If we once again accept that these harmonics are the odd order constituents of an imbedded squarewave, then the even order harmonics must be f_{15} , f_{21} , and f_{27} . Subtracting any one of these harmonic numbers from the next highest leaves a difference of 3SU , and adding 3SU with 1SU produces a sum of 4SU . So, the **SHS** for this harmonic series should be $f(f_4)$, at f_4 , and since $f = 80 \text{ Hz}$, then $f(f_4) = 320 \text{ Hz}$.

9.21 We can see that even though the **SHS** of the **LMA** is not "visible" to the analyzer (or the ear) above the natural slope of decent of the fundamental's harmonic family, the new harmonic family generated by the **SHS**, acting as its own fundamental, is fairly obvious. Moreover, knowing that an **LMA's** **SHS** will generate an imbedded harmonic family with characteristics similar to a squarewave, and will alter the harmonics of the fundamental accordingly, we can apply limit values to just those frequencies, and avoid the use of a comprehensive set of limits across the spectrum. This reduction in the number of frequency points we examine provides three benefits:

- a. It allows for the acceptance of loudspeakers whose fundamental harmonics may vary in amplitude within the expected standard deviation, while still providing close scrutiny over harmonics symptomatic of **LMA**.
- b. It lessens the unpredictable effects of electronic and acoustic noise and distortions
- c. It is simpler and faster than examining all points in the spectrum

9.22 In effect, this is an indirect method by which the system looks for "evidence" of the anomaly rather than the **LMA** itself. As predicted, this is similar to the case of human hearing when a listener mentally extrapolates a "fundamental" from a series of overtones or harmonics. Thus, we have successfully implemented this aspect of our human hearing model.

9.23 The implications are of gravity, because this analysis technique can correctly state the actual frequency/harmonic (**SHS**) at which an **LMA** is originating, even at low **LMA** levels. Since most manufacturers already know the typical causes of **LMAs** in their products (see Sec. 3), parallels could be drawn so as to correlate unique spectral characteristics and combinations of **SHSs** found in specific Acoustic Portraits directly with specific causes of **LMA**. Likewise, the technique would be useful in the case of a new "undefined" production defect by providing a detailed Acoustic Portrait of the developing anomaly. So, combined with the forensic analysis of defective units, it can be seen how an automated procedure using this technique would prove useful. Early forms of this technique have been in use, in whole or in part, at R&D and manufacturing facilities, with satisfactory results.

9.24 Having established a method by which to reliably detect evidence of an **LMA** with a given stimulus frequency, we may put this technique to work on a broader scale. Figures 58-75 are a series of FFTs that compare the spectra of a good compression driver with one exhibiting **LMA**. The LUTs are 1.3" mid-high frequency compression drivers with an 800 Hz frequency cutoff, designed for pro sound, commercial and M.I. applications, with a nominal impedance of 8 Ohms, driven with 2.83 Volts. Test setup conforms to the setup in Appendix 2: A2.1 and A2.3 and the diagrams in Figures 97 and 99. For these comparisons, only the broadband FFTs are shown. The fundamental stimulus frequency is "stepped" throughout the series, and

shows the resulting data for each. The even numbered graphs are the good LUT, the odd numbered graphs, the LUT with LMA. It should be noted that although different in their individual spectra, each FFT in this series showed that the driver with an LMA exhibited increases in upper harmonic energy at all stimulus frequencies.

9.25 This is relevant because prior to the analysis, the listening test that determined that it was defective, also determined that the LMA only became evident when stimulated by frequencies within a restricted band. As discussed in Sec. 5, this suggests that because of the effects of frequency masking, it can be difficult for the ear to identify the presence of undesirable low level artifacts. It certainly seems probable that the belief that frequency dependent LMAs become evident only at certain stimulus frequencies might be a preconception based upon the limitations of human hearing, and that evidence of the LMAs exist, however small, throughout the range of stimulus.

9.26 As demonstrated, although the FFT analysis performed while stimulating the LUT at an individual frequency is very fast, and the resulting data is very detailed, the task of performing the "nested" sweep of FFT's across the spectrum (as in Figures 58-75) could consume several minutes of test time. While this is acceptable and maybe even desirable for R&D and engineering applications, production line applications require much faster testing. Since the prospect of continually sweeping a fundamental across the spectrum while constantly performing FFT analyses vs. "sweeping limits" (pass/fail limits that change for each fundamental of the sweep), whose total performance time is on the order of 3 to 5 seconds is presently impractical, an alternative stimulus technique that allows for comprehensive spectral exercise of the loudspeaker needs to be developed.

10. "LoMAD" Loudspeaker Mechanical Anomaly Detection via "FASTest"®

10.1.0 The method by which this is solved in this study makes use of a DSP based stimulus and response instrument, the Audio Precision® "System One+DSP"®. An accompanying DSP software program for the instrument called "FASTest"®, which was originally designed for electronic audio component and system testing, employs the unique ability to generate a multiple number of constituent sinewaves at precise frequencies simultaneously or "in parallel", while performing FFT analysis vs. limits. While a technical and philosophical departure from past techniques using swept sinewave or spectrally weighted noise as their stimulus, this "parallel" stimulus technique offers several benefits.

- a. It simplifies testing by eliminating the need for a swept fundamental across the spectrum, individual analyses and separate limits
- b. The use of a calibrated, definable, complex waveform provides a stimulus "more like" the complex audio waveforms that the loudspeaker will be subjected to in the course of it's normal life, yet offers the accuracy and control needed for scientific analysis.
- c. It allows us to examine the performance characteristics of the loudspeaker as a whole, in a "working environment"
- d. Its very fast. Stimulus and response are done in parallel so there is no time "penalty" for performing more detailed testing

10.1.1 Under swept sinewave stimulus, the loudspeaker will perform electrically and acoustically in a manner that can be defined via traditional swept response, distortion and impedance tests. However, in the real world applications of reproducing program sound, it is unlikely that these "ideal" characteristics recorded in the lab will be attained. Since electrical impedance and acoustical loading characteristics of a loudspeaker are frequency/amplitude dependant and thus

dynamic, differences loudspeaker performance are expected when comparing the output of a loudspeaker stimulated by a swept sinewave vs. a complex waveform.

10.2 To see how this simultaneous stimulus and response technique works, **Figure 76** shows the FFT analysis of two stimulus frequencies and their resulting harmonics. Note the "picket fence" effect created as the harmonics are interleaved with one another. This is possible when harmonically unrelated fundamentals are selected for stimulus. **Tables 1-2** show the data input (or frequency request) file and subsequent digitally generated frequency source file used in **Figure 77**. The amplitudes of each frequency were specified to conform with the manufacturers "standard" input curve. The phase of each frequency was randomized to reduce waveform crest factor. An analysis "sweep" (**Table 3**) was then created to include harmonics S_{2-14} . So, the FFT in **Figure 76** shows the same compression driver with the high frequency "buzz" used in **Sec. 9**. Only this time, via the digital generator, all nine fundamentals found in **Figures 58-75** were simultaneously applied through the driver. For convenience, the waveform was referenced at 1 kHz = 0 dBr.

10.3 With the ability to perform such stimulus, comes the need to establish some ground rules. In order to successfully implement LoMAD via FASTest®, important questions needed to be addressed.

10.4 Which elements of loudspeaker performance should be tested?

Given the subjective history of loudspeaker testing, and the fact that there is little opportunity for a manufacturer to perform a separate set of tests just for LMAs, a comprehensive procedure was developed to allow for the widest range of use. So, in addition to LMAs, the LoMAD procedure would need to test for sensitivity, polarity and frequency response.

10.5 How long should a test cycle take?

From discussions with many test engineers, it was determined that in order to be of practical use to most manufacturers, test cycle time must stay below 10 seconds, and 3 seconds would be ideal.

10.6.0 Which frequencies should be used for stimulus?

Many combinations of frequencies can be used with LoMAD. The frequency and dynamic range as well as the type and application of the loudspeaker are important considerations. In this case, twenty one "inharmonic" frequencies from approximately 40 Hz through 15 kHz were selected (see **Table 4-5**). Selecting "inharmonic" frequencies is both a requirement and a benefit. It is required so that each frequency has a truly unique harmonic contribution to the composite signal, allowing for maximum discrimination in the analysis. It is a benefit because the resulting signal is "greater than the sum of its parts." Because of complex IM and Doppler/FM², the driver is not only exercised at the selected frequencies, but above, below and in between as well. This helps rest some of the concern that an LMA with a particularly narrow "Q" might not be stimulated.

10.6.1 From 41 Hz to 217 Hz, a "high density cluster" of nine frequencies is used to provide maximum excitation of the diaphragm in the spectral region "notorious" for generating LMAs. These tones will also be used to examine the low frequency response and rolloff of the driver. Since the mid-frequency performance of a driver typically exhibits the least deviation in response, six, more widely spaced frequencies from 463 Hz to 2.3 kHz were selected. These tones provide stimulus for both response measurements and higher frequency LMAs. This wider spacing also creates spectral "holes" so that harmonics from the "high density cluster" are more obvious. At the top of the spectrum, we include six additional frequencies from

2.9 kHz to 14.9 kHz solely for high frequency response and rolloff measurements.

10.7.0 Which frequencies should be selected for analysis?

This is really a multi-part question. Separate frequency tables or "sweeps" need to be used for response and LoMAD. Obviously for the response measurement, we select the twenty one fundamentals in Table 5. However, the frequencies required for LoMAD are a bit more sophisticated.

10.7.1 Recalling Sec. 9.9 - 9.11, LMAs will produce SHSs with accentuated odd order harmonics. These SHS harmonics, although appearing at the same frequencies of fundamental harmonics, are not harmonics of the fundamental. Rather, they are harmonics of harmonics. Hence, the expression $\$(s_n)_x$ was established in Sec. 9.10. Carrying this concept forward, we first edit the top six frequencies out of Table 5 and create a table (Table 6) with just the fundamentals that are of concern to LoMAD. Using a supplied utility program called MAKEDIST.exe, we create a table of fundamental harmonics $[s^{1-15}]_{2-6}$ (Table 7). In Table 8, the top nine frequencies have been removed from Table 7 in order to conform to the maximum number of fifty constituents in the source file for processing by the utility program. This represents no loss, since these frequencies are above 5 kHz and most of their extended harmonic families are well out of the audio band. Now, using the utility program with Table 8 as the source file, we request harmonics s_{2-6} . This yields harmonics $\$([s^{1-15}]_{2-6})_{2-6}$ combined with $[s^{1-15}]_{2-6}$. To extend our LMA analysis a bit further, we add harmonics $[s^{1-15}]_6$ as well as harmonics $\$([s^{1-15}]_6)_{2-6}$. The end result is shown in Table 9 and includes $[s^{1-15}]_{2-6}$ and $\$([s^{1-15}]_{2-6})_{2-6}$.

10.8 How much operator involvement/interaction is desirable?

The degree of operator involvement depends upon the application. So, several variations of the LoMAD procedure were written to allow for an interactive procedure with detailed error reporting and printouts for engineering, to a simple PASS/FAIL procedure for production line testing, needing only a single keystroke to initiate an "endless" test cycle. Only one interactive setup procedure was written for the creation of "limits" and is intended for engineering use only. Examples of these procedures follow in Sec. 11 and Appendices.

10.9 How will the results correlate with existing techniques?

First, not many techniques exist that perform LMA testing. As covered in Sec 5., this is because most LMA detection is still performed by "Listeners." Those that do use equipment usually implement one of the swept techniques described in Sec. 6. In swept stimulus measurements, all the power provided to the loudspeaker is focused on just one fundamental. Since LoMAD via FASTest® uses a complex waveform for stimulus, the RMS amplitude of the waveform is the root-sum-square of all its constituents¹³. For example, as in the case of the 21 tone, equal-amplitude waveform, if the RMS of the waveform was 0 dB, then each constituent would be approximately -22.4 dB below. In other words, if the power amplifier is supplying this waveform to the loudspeaker at 5 V RMS, then each tone would be approximately 380 mV. Further study is required in the area of analyses correlation with other systems/techniques because of the differences in stimulus and analysis techniques.

10.10.0 For clarity, a few items regarding the basic operation of the System One+DSP® and FASTest.dsp program follow.

10.10.1 FASTest.dsp was developed for very rapid frequency response, distortion, noise and inter-channel phase testing of audio systems and equipment. It operates by generating a multi-sinewave signal as stimulus, then performing an FFT analysis of this signal at the output of the device or system under test. The multi-sinewave

signal is defined by a waveform file which must be downloaded to the generator buffer of FASTest.dsp. While several factory configured waveforms are supplied, custom waveforms can be easily created via a supplied utility program named MAKEWAVE.exe. In the creation of a custom waveform, the operator not only has the option to specify the frequencies of the various sinewaves, but amplitude and phase relationships as well. As an added convenience, stimulus and analysis may be made analog or in the digital domain for digital devices.¹³

10.10.2 Since the generator waveform buffer is an exact integer sub-multiple of the acquired signal buffer, stimulus and analysis is synchronous. Because of this, FFT analysis "bins" can correlate precisely with stimulus frequencies, eliminating the need for FFT windowing. The operator selects the data to be analyzed via a data table called a "sweep" file. This is easily accomplished through another accompanying utility program called MAKEDIST.exe. The software then requests only the data from the specific FFT "bins" specified and ignores all other data. Multiple "sweeps" may then be performed on the acquired data stored in the DSP buffer, without the need for further "on-line" testing. So response, distortion and noise measurements may be performed on exactly the same data acquisition.¹³

10.10.3 Of specific interest is a software feature originally developed to assist making FASTest measurements on audio tape recorders and turntables. Because of speed variations, FM of the recorded signal can occur. While the effects of speed related FM in the lower spectrum are fairly minor, this can cause higher frequencies to "miss" their target FFT analysis bin and spread their energy across several adjacent bins. To counter this effect, a feature called RESPwW+F (Response with Wow and Flutter) was implemented. This allows the operator to specify adjacent bins for analysis, within a user specified +/- percent. The DSP then computes the RSS (root-sum-square) of the specified bins, and allows for the effective "re-capture" of energy lost to sidebands.¹³

10.10.4 This is an important addition for the acquisition of signal for LoMAD procedures. Since a loudspeaker stimulated with a complex waveform will exhibit varying degrees of measurable Doppler/frequency modulation (see Sec. 6.9, Figures 16-17)², this feature allows for the "re-capture" of energy lost to sidebands in the same way that it is accomplished above.

11. "LoMAD" SETUP & TEST PROCEDURES

11.1 Appendix 3 shows setup procedure RBF-CAL.PRO in its entirety. This is the automated testing and data input "program" used to create the Pass/Fail limit files for frequency response, phase/polarity and LMA for subsequent production tests and procedures. It can test and incorporate the data from virtually any number of loudspeakers selected for "good" reference units. Thus, the more speakers surveyed, the more representative the limit files are of the product line. Comments in the right column of the procedure, delimited by the ";", provide a step-by-step/line-by-line explanation of the processes in the procedure. It will suffice to say here that response and phase/polarity limits are an average of all the sample units, (+/-) user defined values, and LMA limits are a "tally" of the maximum distortion levels achieved from throughout the sample units at each of the selected harmonics, (+) a user defined value.

11.2 With limits established, procedures to provide testing vs. limits and pass/fail analysis are then employed. Since the need for detailed test result data varies based upon application, (R & D, Engineering, QC, Manufacturing, etc.) six procedures were developed to fulfill this range of needs. Appendix 4 is the test procedure RBFPS-6.PRO, which is tailored for production line testing. Operator involvement is held to simply pressing the <Enter> key. The acquisition process,

or time that the LUT must be connected, is less about 2 seconds, and subsequent PC time (on a 16MHz 80286 w/80287) for data "crunching" and pass/fail prompting ranges from 1 to 3 seconds, yielding a worst case run time of about 5 seconds. Test cycle time will decrease with faster computers.

11.4 As mentioned, there are five other variations of this procedure with varying run times and operator involvement. Parties interested in examining these other procedures are invited to contact the authors for printed copies.

12. LoMAD QC TESTING RESULTS

12.1 Figures 78-96 are a series showing the test results from nine loudspeakers using LoMAD procedure RBFPS-6.PRO. The loudspeaker model is the same 4 $\frac{1}{2}$ driver described in Sec. 9.4. The test setup again conforms to the setup in Appendix 2: Sec. A2.1-A2.2 and the diagrams in Figures 97-98. The limits for PASS/FAIL were created using the LoMAD setup procedure RBF-CAL.pro described in Sec. 11, and used five "known good" loudspeakers as reference. These are not anechoic measurements, so these graphs do not necessarily represent the "actual" characteristics of the drivers. Rather, they show the combined effect of their performance and behavior within the test environment. To establish an appropriate reference, the accepted technique of using "known good" loudspeakers as a "transfer standard" was used to characterize the good loudspeaker/environment for proper testing.

12.2 Each loudspeaker was tested for sensitivity, polarity, response and LMAs. To assure repeatable data, the test procedure was performed repeatedly on "nearly" a daily basis for a period of about 2 weeks. During this time, the good LUTs always passed, the defective LUTs always failed. About 45 days after this initial test period, and having disassembled and re-assembled the test fixture, the procedure was performed again on the same drivers. The good LUTs passed, the defective LUTs failed. Thus, the data in the following graphs is typical, and required no special "attention" for these results.

12.3 Since the sensitivity and polarity tests are just single point PASS/FAIL tests, the limits (at top), and results for all nine of these tests are combined in Figure 96. It should be mentioned that all nine passed these tests. For the balance of the tests, the even numbered figures (above) show the frequency response of the drivers vs. limits, and odd numbered figures (below) the LMA analysis vs. limits.

12.4 The first three sets of graphs (Figures 78-83) show three of the good loudspeakers. The remaining six have defects and exhibit various degrees of LMAs.

Unit #4: Figures 84-85, Voice coil "rub;" This LUT failed both the response and distortion tests.

Unit #5: Figures 86-87, Mid frequency "buzz;" This driver passed the response test but failed the distortion test at 5 or 6 points. Among the points that it failed, there are some shared frequencies with the "rub" in Unit #4, but the harmonics that caused it to fail don't continue as high.

Unit #6: Figures 88-89, Magnet chips-rattle; This was a good example of a frequency independent LMA. We purposely broke off pieces of the magnet and trapped them within the magnetic field between the spider and the cone. Rather than "buzzing" at any frequency, they just bounced around randomly like jewels in a tumbler. It passed response, but the

distortion graph shows a picture of the random broadband "pulses" it created, and caused it to fail.

Unit #7: **Figures 90-91**, Voice coil "rub"; On this rub, the LUT barely passed the response test. But note the strong similarity in the response curve as compared to Unit #4. Like Unit #4, it failed the distortion test, and at the same frequencies.

Unit #8: **Figures 92-93**, Tear in spider; Like Unit #6, the defect in this LUT was "prepared" Two cuts were made in the spider to allow it to flap against itself. This also caused the voice coil to ride off center and increased trans-axial movement. It failed handily in both the response and distortion test. This unit failed at the greatest number of points, because it possessed several different types of **LMAs**.

Unit #9: **Figures 94-95**, Hole in dust cap; This was an otherwise good LUT that had a small pinhole pierced in it's dust cap. Note that the response curve almost matches those of the good units until about 4 kHz where it dips down only to rise quickly up to 15 kHz. Although marginal, it did pass the response test. However, the hole caused a "whistle" and was detected at about 8 frequencies starting at just under 900 Hz.

12.5 The final measure of any technique is how well it works. In light of the previous examples, it can be said that **LoMAD** via **FASTest** provides a quick and repeatable means of evaluating loudspeaker performance, including the reliable means of detecting Loudspeaker Mechanical Anomalies ("rub" and "buzz").

13. CONCLUSIONS

13.1 Although different in their applications of the technology, the motor drive sections in direct radiators and compression drivers share many similarities in operation and risk of **LMAs**, and may be tested in a similar fashion.

13.2 **Sec. 3** resolved that the greatest contributions of loudspeaker anomalies result from abnormalities in the loudspeaker's mechanical system, including certain electrical and acoustical anomalies that may have their origin in some type of mechanical displacement.

13.3 **Sec. 5** applauds the meritorious past performance of human hearing in **LMA** testing, yet prompts us to find a way to integrate positive aspects of hearing into an ATE system for more reliable and repeatable testing. Reasons are given, beyond the risk of hearing loss, why "Listeners" should not be used as the primary instruments for loudspeaker testing. Notable are limitations due to aural masking and the fact that this subjective method offers little control over QC standards.

13.4 **Sec. 6** demonstrated that to achieve comprehensive **LMA** detection requires a complex analysis technique (like FFT), similar in sophistication to the human ear, that allows for "parallel" analysis of a broad range of frequency/amplitude constituents. Attempts to isolate these anomalies by other less sophisticated means were simply not as effective.

13.5 The experiment in **Sec. 8** has yielded that **LMAs** produce waveforms and spectral families like those of a band limited squarewave. The degree of waveform "square-

ness" is dependent upon the spectral "placement" of the **Secondary Harmonic Source(s)** with respect to the fundamental and is proportional to the severity of the anomaly. This is because the **LMA** is caused by some physical impedance or point of resistance within the physical structure of the loudspeaker, and when the loudspeaker goes through its normal excursion, the resistive point is encountered, triggering an extremely short "pulse" of energy with broadband spectral components, at some derivative of the fundamental rate. The band-limiting effect is due to the response performance characteristics of the individual loudspeaker, and as such, will vary. It has also been demonstrated that **LMA SHSs** are harmonically related to the stimulus frequency by virtue of origin, and share at least part of the fundamental's harmonic family.

13.6 Sec. 9 showed the successful implementation of single tone stimulus and FFT analysis of **LMAs** in compression drivers. It was also determined that although **LMAs** had a life of their own, evidence of their existence could be fairly imbedded within the harmonics of the fundamental, making detection difficult. Unfortunately from a forensic viewpoint, it is impossible to "surgically" remove the fundamental and its "normal" harmonics from the loudspeaker while allowing the **LMA** to stay active for study. This is because, "The **LMA** is more like a virus than a bacteria, and ceases to live upon the death of its host." However, a technique was demonstrated which combined FFT and Delta analysis, with the implementation of a concept from human hearing that allows for the extrapolation of unheard frequencies based on those perceived. Thus, it was possible to detect low level evidence of **LMAs** and determine their **SHSs**.

13.7 In Sec. 12 it was demonstrated that a fast, reliable, and comprehensive test procedure could be engineered for loudspeakers with **LoMAD** via **FASTest®**, a complex waveform stimulus and scheduled FFT analysis technique. Furthermore, the quality and extent of data provided about the symptoms of loudspeaker defects is extremely comprehensive. Because this system is optimized for engineering and high speed **QC** applications, maximum benefit can be realized by fully integrating it within the engineering/manufacturing chain.

* * *

NOTICES

B&K® is a trademark of Bruel & Kæj
COMPAQ Portable II® is a trademark of COMPAQ Computers
EV® is a trademark of Electro-Voice
Hafler® is a trademark of Hafler
ITE/In-The-Ear® Microphone are trademarks of Etymotic Research
Micro Express® is a trademark of Micro Express Computers
Motorola® DSP 56001® are trademarks of Motorola, Inc.
PZM® is a trademark of Crown International
QSC® is a trademark of QSC, Inc.
System One®, System One + DSP® and FASTest® are trademarks of Audio Precision, Inc.
UREI® is a trademark of UREI, a Harman International Company

ACKNOWLEDGMENTS

The authors wish to extend their deepest gratitude to our many colleagues, whom over the last 20 months have contributed so generously in the way of information, references, ideas, resources and of course, themselves. It is proper and uplifting to note, that a certain "spirit" was evidenced throughout the process of amassing the information for this paper, which allowed managers, engineers and technicians from many companies, some competitors in the field, to lend assistance knowingly and freely, and without prejudice. We hope we did right by ya'll.
Thanks! GG, MB, TB, JB.

Additional research and documentation provided by:
Gary Ewald, Electro-Voice

For System One®, Applications Software and Assistance: (alphabetical)
Debbie Brimacombe, **Dr. Richard Cabot**, **Tony Dal Molin**, **Louis Eagle**, **Bruce Hofer**,
Carl Hovey, **Bob Metzler**, **Tom Mintner**, **Bill Rich**, **Rick Swimm**, **Robert Wright**

For Project Support:

Douglas F. Ordon
Douglas Ordon and Company

Dick Auerbach
Harman-Motive

Al Watson
Electro-Voice

Additional Project Support:

Paul Fidlin, **Ray Newman**

Instrumentalists: Oboe **Marcie Papadaikas**, Flute **Brenda Groeper**
Oboe Courtesy: **The Instrument Shop**, Chicago, IL
Laser Printer Courtesy: **Caryn Schmidt**

For additional product test sample and/or general contributions: (alphabetical)
The American Loudspeaker Manufacturer's Assn. (ALMA), **International Jensen®**, **Misco®**,
MTX/Oaktron®, **Oxford Loudspeaker Company®**, **Pyle® Industries**, **Rockford-Carbonneau®**

REFERENCES

¹ AES Standards Committee, Working Group on Sound Reinforcement Components, Clifford A. Henrickson, Chair, "AES-11D-1991, Plane Wave Tubes: Design and Practice," Journal-Audio Eng. Society, 39, 6, 1991

² Allison, R., "On the Magnitude and Audibility of FM Distortion in Loudspeakers," Journal-Audio Eng. Society 30(10), 1982

- ³ Breithaupt, Thomas D., "In-Car Early Reflection Studies Using In-The-Ear Microphone Techniques, Presented February 3rd 1991, AES 9th International Conference, Detroit, MI
- ⁴ Cabot, Richard C., "Limitations of Digital Filter Architectures", Presented at the 89th Convention of the Audio Eng. Society, Preprint #2964, 1990
- ⁵ -----, Appendix One: "Automated Measurements of Loudspeaker Small Signal Parameters," from "Loudspeaker Testing with System One," Audio Precision Applications Note 2, © 1989 Audio Precision, Inc., Beaverton, OR
- ⁶ Clark, David, "Measuring Drive-Unit Motor Linearity" Presented February 3rd 1991, AES 9th International Conference, Detroit, MI
- ⁷ Dolby, Ray M., "A 20 dB Noise Reduction System for Consumer Tape Applications," Journal-Audio Eng. Society, Presented at the 70th Convention of the Audio Eng. Soc., 1981, New York
- ⁸ Gundry, Kenneth J. and Joseph Null, "Introducing Dolby S-Type Noise Reduction," Audio, June 1990 © Diamandis Communications, Inc.
- ⁹ Hall, Donald E., Musical Acoustics: An Introduction, Wadsworth, Belmont, CA 1980
- ¹⁰ International Organization for Standardization (ISO), Normal Equal Loudness for Pure Tones and Normal Threshold for Hearing under Free Field Listening Conditions, Recommendation R226, Dec. 1961 © the American National Standards Institute, New York, NY
- ¹¹ Metzler, Robert E., "Loudspeaker Testing with System One", Audio Precision Applications Note 2, © 1989 Audio Precision, Inc., Beaverton, OR
- ¹² -----, System One Users Manual, Rev.11, © August 1989 Audio Precision, Inc., Beaverton, OR
- ¹³ -----, DSP Users Manual, © August 1989 Audio Precision, Inc., Beaverton, OR
- ¹⁴ Robinson, D. W., and R. S. Dadson, "A Re-Determination of the Equal-Loudness Relations for Pure Tones," British Journal of Applied Physics, vol. 7, pp 166-181, 1956 (Adopted by the International Organization for Standardization (ISO), as Recommendation R226)
- ¹⁵ Satoh, Katsuaki, K. Blair Benson (Ed), "Sound Reproduction Devices and Systems" Audio Engineering Handbook, Sec. 7.4.4, 7.6.4, McGraw-Hill, New York, 1988
- ¹⁶ Stevens, S. S., and J. Volkman, "The Relation of Pitch to Frequency: a Revised Scale," American Journal of Psychology, vol. 53, pp 329-353, 1940
- ¹⁷ Toole, Floyd E., K. Blair Benson (Ed), "Principals of Sound and Hearing" Audio Engineering Handbook, Sec. 1.8.2, 1.8.4, McGraw-Hill, New York, 1988
- ¹⁸ -----, "Loudspeaker Measurements and Their Relationship to Listener Preferences", Journal-Audio Eng. Society, 34, 1986
- ¹⁹ Zwicker, E., G. Flattorp and S. S. Stevens, "Critical Bandwidth in Loudness Summation," Journal of the ASA, vol. 19, pp 780-797, May 1957

APPENDIX 1: PROJECT HISTORY/BACKGROUND

The tests and experiments covered in this paper were conducted at three separate facilities in the USA: Electro-Voice, Buchanan, Michigan; Harman-Motive, Martinsville, Indiana; and Douglas Ordon & Company, Chicago, Illinois.

The process of developing a new method of automated **LMA** testing using DSP began in late 1989, in response to independent, yet simultaneous requests from Electro-Voice and Harman-Motive to Audio Precision® Midwest Reps, Douglas Ordon and Company. Each was interested in increasing their current testing capabilities further by using some new yet-to-be defined technique. Having worked for years with some of the most sophisticated analog instrumentation and techniques available, they recognized that Audio Precision's® DSP based "System One+DSP"® would be a good platform for developing these new techniques.

In response, research into test requirements, viability, application of techniques, development and specification of the tests and procedures for **LMA** testing (**LoMAD**) was initiated in February 1990 by Gregory G. Groeper, Audio Precision Product Specialist at Douglas Ordon and Company. To accomplish the appointed goals, human and technical resources were provided on an open basis at each facility. At Electro-Voice, Mark A. Blanchard and at Harman-Motive, Terry Brummett and Jeff Bailey were on the case.

Having both companies in pursuit of "the next generation" of loudspeaker testing was an ideal coincidence. Electro-Voice, in the professional audio market, and Harman-Motive, in the auto/OEM audio market, were comprised of some of the most knowledgeable people in the loudspeaker industry. Working independently of each other, it was possible to conduct parallel, yet specialized research into the development of testing techniques and procedures. Since they also both owned identical Audio Precision® systems, correlating and transferring test results was simplified tremendously.

In April 1990, the authors' first use of FFT analysis for **LMA** testing in the field, was conducted at the Anechoic/Acoustic Laboratory at Electro-Voice. In the following weeks, similar testing began at Harman-Motive ES Lab. By this time, it was evident that the best implementation the available hardware should incorporate several elements of human hearing in the analysis process.

While the analysis techniques matured, FASTest® software was introduced by Dr. Richard C. Cabot, et. al., Audio Precision, Inc.. This made it possible for System One+DSP® to digitally generate, definable complex (multi-tone) waveforms and simultaneously perform analysis via FFT and specified frequency tables. This was immediately incorporated into the existing analysis techniques.

Experimentation and further refinement of **LoMAD** techniques and procedures (now using FASTest® software) for dynamic type-direct radiator loudspeakers, was conducted at the Harman-Motive ES Lab and at Douglas Ordon & Company, while at the Electro-Voice Anechoic/Acoustic Laboratory, the same progress was being made with compression drivers.

In March 1991, having gained positive results, the collective decision was made to combine all the research from each of the respective companies and present these findings to the 91st Convention of the Audio Engineering Society.

A preliminary version of the **LoMAD** FFT analysis technique was implemented for production line testing at Electro-Voice earlier this year.

APPENDIX 2: TEST SETUPS/EQUIPMENT USED

A2.1 Figure 97 shows the basic test setup used for all the tests covered in this paper. The Audio Precision "System One + DSP"® (SYS-222), a PC computer controlled, automated test system was selected for the audio stimulus/response system. The "S1"® software used to operate the hardware and perform analysis is supplied by Audio Precision as part of this system. In addition to conventional audio test instrumentation, "System One + DSP"® has the added feature of having a Motorola 56001® (x 2) based DSP module fully integrated within the system. The system (as configured here) provides 2 channels of analog audio input and output, including the ability to internally route digitally generated waveforms from the output of the (DSP) digital signal generator through a 16 bit D/A converter to the balanced line audio outputs of the instrument. Input facilities are equally flexible, allowing the choice of routing the signal to the analog section of the instrument (for level, phase, power, etc.) or internally piping signal to the (DSP) via 16 bit A/D converters for dual channel FFT, dual channel waveform analysis and selectable harmonic analysis via high Q digital filters.¹²

A2.2 Figure 98 shows a diagram of the test fixture used at Douglas Ordon & Company, and was the test fixture used for the majority of the direct radiation type loudspeaker tests included in this paper. The test box consisted of high density corrugated cardboard. The sides were treated with sheets of polyfoam acoustic absorbing material.

Computer: Compaq Portable II® w/80286/80287 processors
Microphone: (PZM)®, Pressure Zone Microphones® -Crown (modified for bal.output)
Pre Amp: None
Amplifier: Hafler® DH500

A2.3 Figure 99 shows the Electro-Voice test fixture setup used for all the testing of compression drivers. The fixture consists of a 1" I.D. x 20' plane wave tube load¹ which presents the driver with a uniform acoustical load across the frequency range of the driver. The "business end" of the tube is fitted with a 1.3" threaded joint for attaching the driver. The microphone is then inserted into the tube at the point of the driver exit, through an precise opening. Once in place, the mic and surrounding gasket form an airtight seal.

Computer: Zeos 286® w/80286/80287 processors
Microphone: B&K® Model 4138 (1/8") w/Model 2916 Emitter/Follower
Pre Amp: B&K® Model 2010 Hetrodyne Analyzer (Pre Amp section only)
Amplifier: QSC® Model 3500

A2.4 Figure 100 shows the Harman-Motive test fixture setup, an anechoic chamber approximately 15' x 15' x 10' used for identifying and quantifying the various types of defects, developing limits for tests as well as correlating results between the anechoic room and the (DOC) test fixture for direct radiation type loudspeakers. The opening to the chamber features a template jig so that different loudspeaker templates can be attached and thus provide the proper seal for the various shapes and sizes of loudspeakers. The microphone is shock mounted and placed at 1 foot behind the template.

Computer: Micro Express® w/80386/80387 processors
Microphone: B&K® Model 4133 (1/4")
Pre Amp: B&K® Model 2807
Amplifier: UREI® 6300

APPENDIX 3: "LoMAD" SETUP PROCEDURE

```

PROCEDUREv2.00                                ;procedure name: RBF-CAL.PRO
                                                ;NOTE: creates limit files for response and
                                                ;      rub & buzz distortion by averaging data
                                                ;      from an assortment of reference speakers
                                                ;
                                                ;      runs test display (graphs)
                                                ;      interactive operator prompts
                                                ;      servos gen to desired level at DUT
                                                ;      run time: depends on number of speakers
                                                ;      tested for averaging
                                                ;      for lab/QC engineer use
;-----
:TOP/R                                         ;logic label: start of procedure

UTIL PROMPT/R                                ;pause for message to operator
/R/R/R

THIS PROCEDURE WILL AVERAGE THE DATA FROM (5) REFERENCE/R
SPEAKERS AND CREATE YOUR LIMIT FILES FOR FREQUENCY/R
RESPONSE, POLARITY AND RUB AND BUZZ DISTORTION./R/R/R
PRESS <1> TO RUN ENTIRE PROCEDURE,/R/R
PRESS <2> TO SKIP ACQUISITION AND PROCESS DATA ON FILE, OR/R/R
PRESS <ESC> TO QUIT PROCEDURE AND RETURN TO MAIN MENU/C10/E

IF 0[UTIL BREAK/R]                            ;end procedure & return to main menu line
IF 1[UTIL GOTO FP1/R]                          ;jump to label FP1, begin testing
IF 2[UTIL GOTO RBFAVG/R]                       ;jump to label RBFAVG, skip testing & compute
                                                ;new limits
;-----
:FP1/R                                         ;logic label: start of frequency response section
UTIL PROMPT/R                                ;pause for message to operator
/R/R

PLACE SPEAKER ON TEST FIXTURE AND/R/R
PRESS <ENTER> WHEN READY TO PROCEED./E

LOAD TEST RBF21CAL/R                          ;load basic test "template" w/no display
LOAD WAVEFORM RBF21/R                         ;load 21 component complex waveform
1G/R                                           ;define waveform buffer to generate
PANEL/R                                       ;call up control panel
/C3/R                                         ;servo generator amplitude to pre-determined level
LC /R                                         ;change primary analysis channel to input A
LB /R/E                                       ;change source of input B to GEN-MON from INPUT
/F4/F9/A8/F1/E                               ;set dBc, run test, store graph, turn off generator
COMPUTE SMOOTH 1,1/R                          ;perform running 3 point average of data
/FB/F7/F10/E                                  ;display pre-smoothed data, & smoothed data
SAVE DATA FP# /F10/R/Y                       ;pause to allow operator to correctly number (FP#___)
                                                ;and save data

```

APPENDIX 3: "LoMAD" SETUP PROCEDURE

```

;-----
:RB1/R                                ;logic label: start of rub & buzz section
PANEL/R                               ;call-up control panel
S2 /R/E                               ;turn off data 2 (phase)
NAMES SWEEP RBF21H5-/R               ;attach sweep table for rub & buzz analysis
/F6/AB/E                             ;rerun stored data w/new swp table, store graph
COMPUTE SMOOTH 1,1/R                ;perform running 3 point average of data
/FB/F7/F10/E                         ;display pre-smoothed data, & smoothed data
SAVE DATA RB# /F10/R               ;pause to allow operator to correctly number (RB#___)
                                     ;and save data

UTIL PROMPT/R                        ;pause for message to operator
/R/R

PRESS <1> TO TEST NEXT SPEAKER FOR AVERAGING,/R/R
PRESS <2> TO RUN DATA AVERAGING PROGRAM, OR/R/R
PRESS <ESC> TO QUIT PROCEDURE AND RETURN TO MAIN MENU/C10/E

IF 0[UTIL BREAK/R]                   ;end procedure & return to main menu line
IF 1[UTIL GOTO FP1/R]                 ;jump to label FP1, begin testing
IF 2[UTIL GOTO RBFVAVG/R]             ;jump to label RBFVAVG, skip testing & compute
                                     ;new limits

;-----
:RBFVAVG/R                            ;logic label: start of BASIC data averaging
DOS BASICA FP/R                       ;exit to DOS, run averaging ;program that creates
                                     ;+/- limit file data for response & phase
DOS BASICA RB/R                       ;exit to DOS, run averaging ;program that creates
                                     ;+ limit file data for Rub & Buzz distortion

;-----
:DAT2LIM                              ;logic label: start of make limit file

LOAD LIMIT 21FPH-U/R                 ;load response/phase upper limit file
LOAD DATA FP-U/R                    ;load upper limit data created by BASIC program
COMPUTE SMOOTH 1,1/R                 ;perform running 3 point average of data 1
COMPUTE DELTA 2/R                    ;compute delta for data 2 (adds +15 degrees)
SAVE LIMIT 21FPH-U/R                 ;save limit with new limit data

LOAD LIMIT 21FPH-L/R                 ;load response/phase lower limit file
LOAD DATA FP-L/R                    ;load lower limit data created by BASIC program
COMPUTE SMOOTH 1,1/R                 ;perform running 3 point average of data 1
COMPUTE DELTA 2/R                    ;compute delta for data 2 (adds -15 degrees)
SAVE LIMIT 21FPH-L/R                 ;save limit with new limit data

LOAD LIMIT RBF21H5X/R                ;load Rub & Buzz upper limit file
LOAD DATA RB-U/R                    ;load lower limit data created by BASIC program
COMPUTE SMOOTH 1,1/R                 ;perform running 3 point average of data 1
SAVE LIMIT RBF21H5X/R                ;save limit with new limit data

```

APPENDIX 3: "LoMAD" SETUP PROCEDURE

```

;-----
:AVGMSG/R                                ;logic label: start of final review section

UTIL PROMPT/R                            ;pause for message to operator
/R/R

REFERENCE SPEAKER DATA HAS BEEN AVERAGED AND LIMITS CREATED./R/R/R
PRESS <1> TO VIEW YOUR LIMIT FILES,/R/R
PRESS <2> TO AUTOMATICALLY LOAD PROCEDURE RBFPS-1 AND/R
PERFORM TEST RUN ON SPEAKER USING NEW LIMITS,/R/R
PRESS <3> TO RE-RUN AVERAGING PROCEDURE AND CREATE NEW LIMITS/R/R
PRESS <ESC> TO QUIT PROCEDURE AND RETURN TO MAIN MENU/C10/E

IF 0[UTIL BREAK/R]                       ;end procedure & return to main menu line
IF 1[LOAD TEST RBF21SRC/R                ;load test template
/F1/A7/F10/E                             ;turn off gen, graph response/phase limits, pause
NAMES SWEEP RBF21H5X/R                   ;attach Rub & Buzz sweep table to test
NAMES UPPER RBF21H5X/R                   ;attach Rub & Buzz upper limit to test
NAMES LOWER L/R                           ;clear lower limit
PANEL S2 /R                               ;call-up control panel
/A7/F10/E                                 ;graph Rub & Buzz limit, pause
UTIL GOTO AVGMSG/R]                       ;loop-back to label AVGMSG (start of this section)
IF 2[RUN CALL RBFPS-1/R]                  ;jump out of this procedure to try out limits in
                                           ;actual test procedure
IF 3[UTIL GOTO TOP/R]                     ;jump to label TOP at start of this procedure
UTIL END                                   ;end of procedure

```

APPENDIX 4: "LoMAD" PRODUCTION LINE PROCEDURE

```

PROCEDUREv2.00                                ;procedure name: RBFPS-#6.PRO
;NOTE: does not use compute smooth on R&B
;       no second test pass on failures
;       runs no test display (graphs)
;       no interactive operator prompts
;       no error reporting file
;       no gen servo, preset level
;       no discrete sens/polarity test,
;       polarity is checked within response test
;       frequency response test,
;       rub & buzz distortion test
;       run time: apx 5-9 sec w/2B6/87, best for
;       high volume production testing
;NOTE: speaker is driven for only 3 sec, so new unit
;       may be connected while operator awaits
;       pass/fail notification

```

```

:TOP/R                                         ;logic label: start of procedure

```

```

UTIL PROMPT/R                                ;pause for message to operator
/R/R/R

```

```

        PLACE NEXT SPEAKER TO TEST ON TEST FIXTURE AND/R/R
        PRESS <ENTER> WHEN READY TO PROCEED./E

```

```

:CAL/R                                         ;logic label: generator servo/cal section

```

```

LOAD TEST RBFSRV#6/R                          ;load basic test "template" w/no display
LOAD WAVEFORM RBF21/R                          ;load 21 component complex waveform
1G/R                                           ;define waveform buffer to generate

```

```

:FRQ1/R                                       ;logic label: start of response section

```

```

NAMES RENAME RBF21FRQ/R                       ;rename test to RBF21FRQ.tst
/F4/F9/F1/E                                   ;set dBr, run test (acquire/store data), gen off
COMPUTE SMOOTH 1,1/R                          ;perform running 3 point average of data
COMPUTE CENTER 1/R                             ;reposition data for "best fit" between limits
NAMES UPPER 21FPH-U/R                         ;attach upper limit for frequency response
NAMES LOWER 21FPH-L/R                         ;attach lower limit for frequency response
/F7/E                                         ;reprocess modified data vs new limits

```

```

IF ERROR{                                     ;logical "if error" statement proceeds to...

```

```

:FRQ-FAIL/R                                   ;logic label: frequency response failure

```

```

UTIL PROMPT/R                                ;pause & prompt operator for next DUT
/R

```

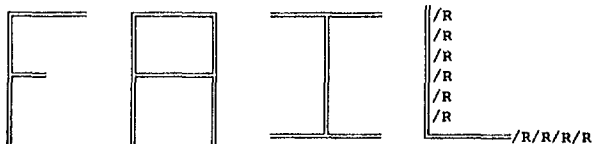

```

        SPEAKER FAILED FREQUENCY RESPONSE TEST/R/R
        REMOVE AND PLACE IN FAILURE #2 BIN. /R/R/R
        PLACE NEXT SPEAKER TO TEST ON TEST FIXTURE AND/R/R
        PRESS <ENTER> WHEN READY TO PROCEED./E

```

APPENDIX 4: "LoMAD" PRODUCTION LINE PROCEDURE

```

UTIL GOTO CAL/R]           ;jump to label CAL

IF NOTERROR[              ;logical "if not error" statement proceeds to...
UTIL GOTO RB1/R]          ;jump to label RB1, rub & buzz analysis

```

```

;-----
:RB1/R                     ;logic label: start of rub & buzz section

NAMES RENAME RBF21R&B/R   ;rename test to RBF21R&B.tst
NAMES LOWER L/R           ;detach lower limit file from test
NAMES UPPER RBF21H5X/R    ;attach upper limit for rub & buzz analysis
NAMES SWEEP RBF21H5-/R    ;attach sweep table for rub & buzz analysis
/F6/E                     ;rerun stored data w/new swp table vs limits

IF ERROR[                 ;logical "if error" statement proceeds to...

```

```

;-----
:RB-FAIL/R                ;logic label: rub & buzz failure

UTIL PROMPT/R            ;pause & prompt operator for next DUT
/R

```

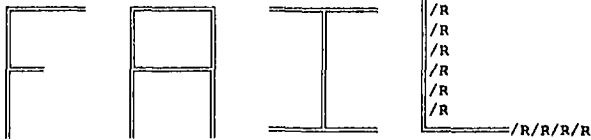

SPEAKER FAILED RUB AND BUZZ TEST,/R/R
 REMOVE AND PLACE IN FAILURE #3 BIN. /R/R/R
 PLACE NEXT SPEAKER TO TEST ON TEST FIXTURE AND/R/R
 PRESS <ENTER> WHEN READY TO PROCEED./E

```

UTIL GOTO CAL/R]         ;jump to label CAL

IF NOTERROR[            ;logical "if not error" statement proceeds to...
UTIL GOTO PASS/R]       ;jump to label PASS

```

```

;-----
:SW/R                   ;logical label: view error report
UTIL GOTO CAL/R         ;jump back (loop) to start label CAL
UTIL END                ;end of procedure (a)

```

```

;-----
:PASS/R                 ;logical label: passed all tests
UTIL PROMPT/R          ;pause & prompt operator for input
/R/R

```

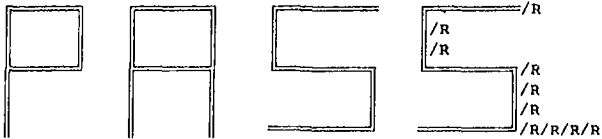

PLACE NEXT SPEAKER TO TEST ON TEST FIXTURE AND/R/R
 PRESS ENTER WHEN READY TO PROCEED./E

```

UTIL GOTO CAL/R]       ;jump back (loop) to start label CAL
UTIL END               ;end of procedure (b)

```

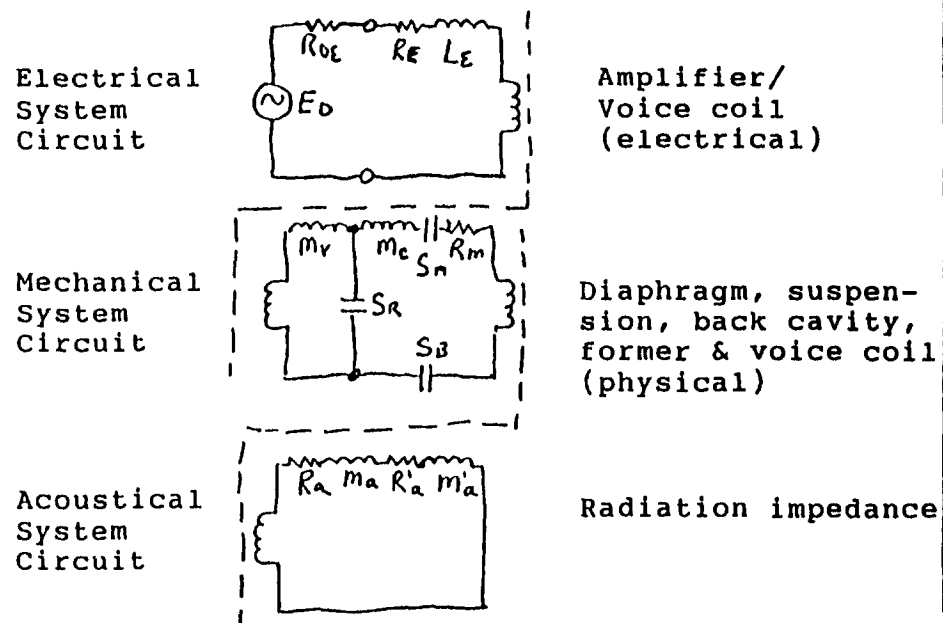
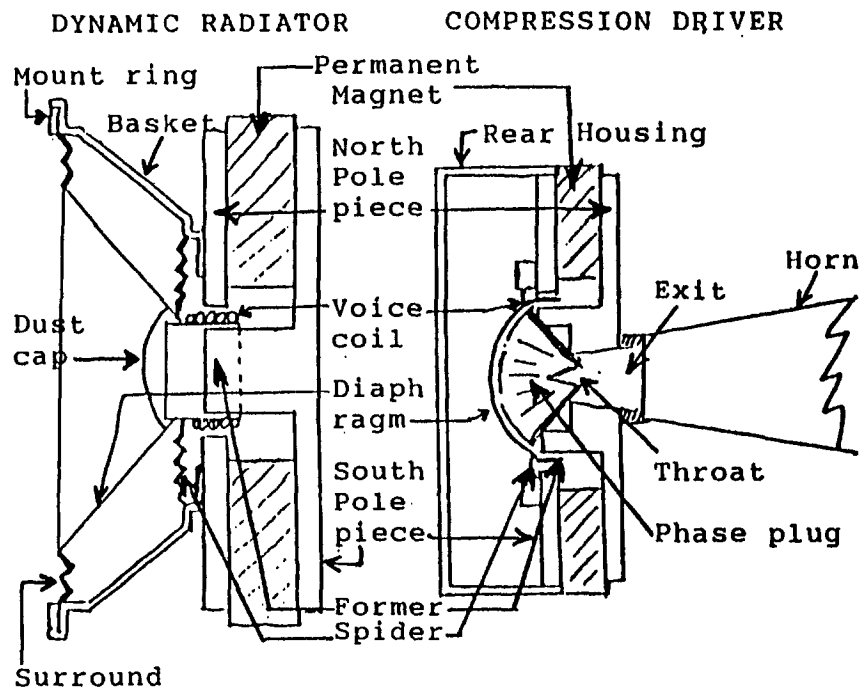

Figure 1: See Section 3.1

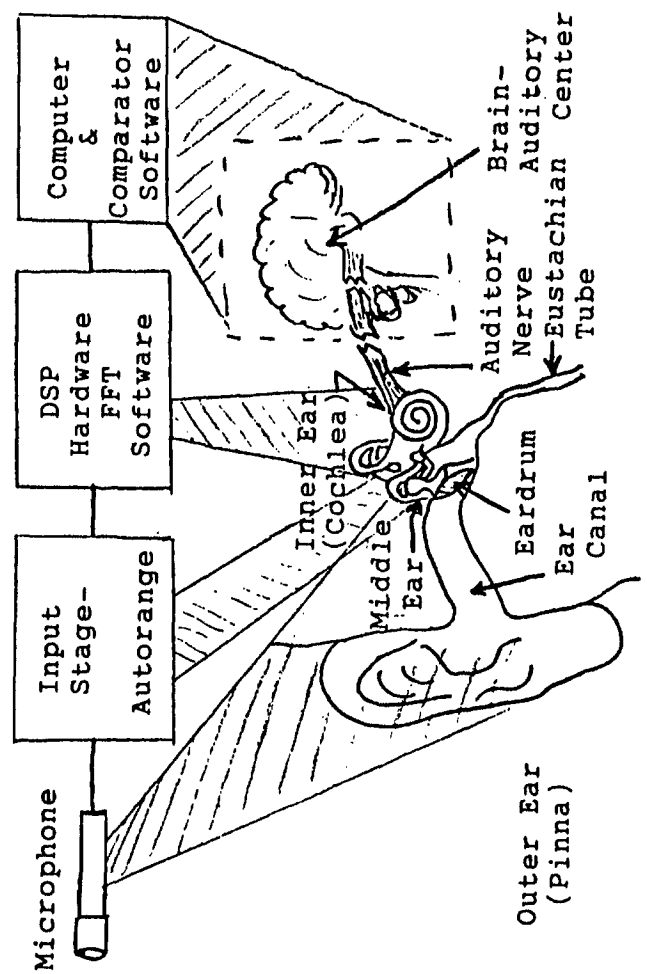

Figure 2: See Section 5.1

FIGURE: 2 Cross section of Ear as compared with corresponding audio analysis components.

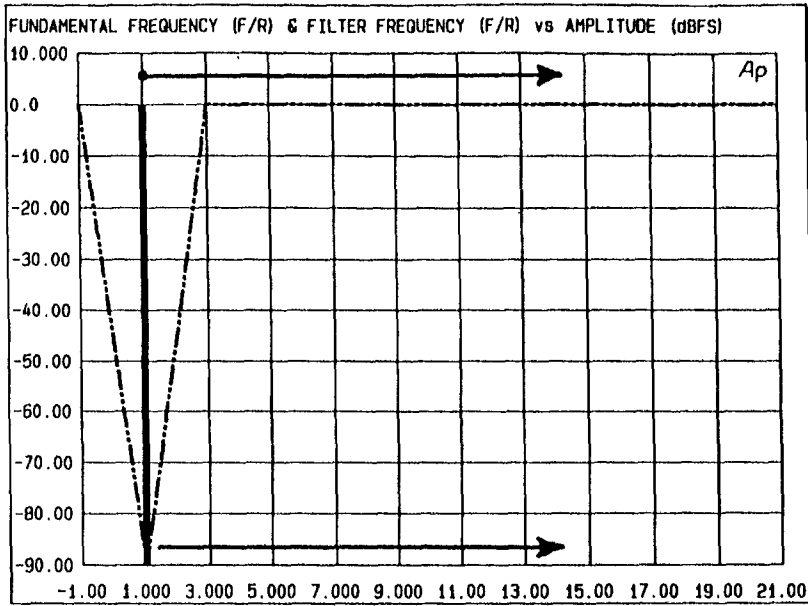

Figure 3: See Section 6.1

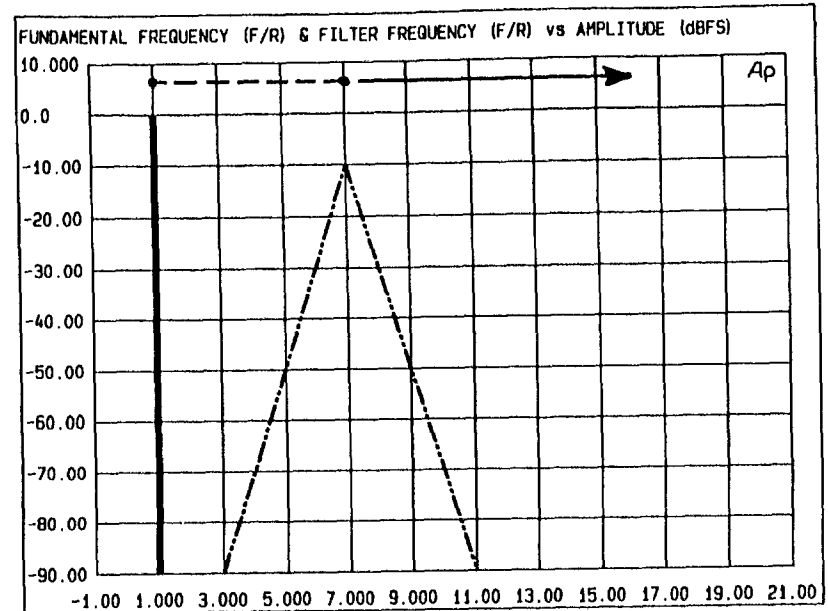

Figure 5: See Section 6.1

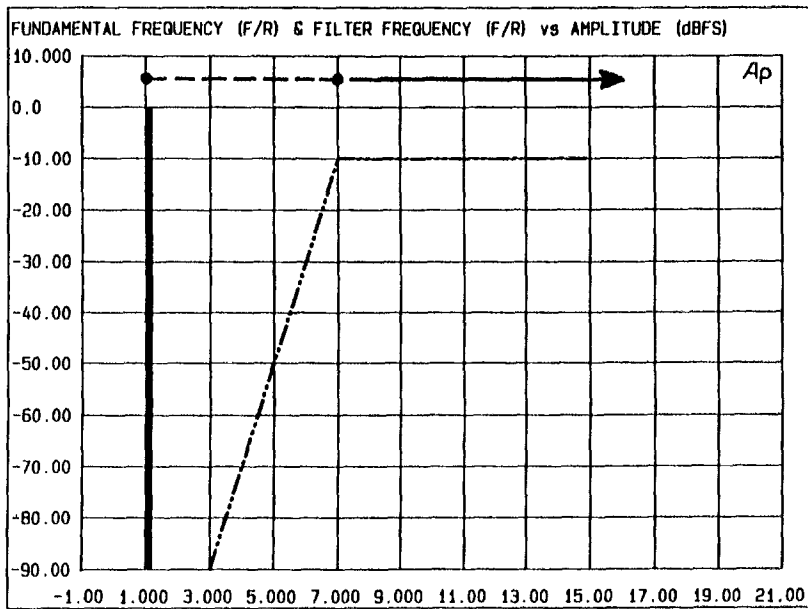

Figure 4: See Section 6.1

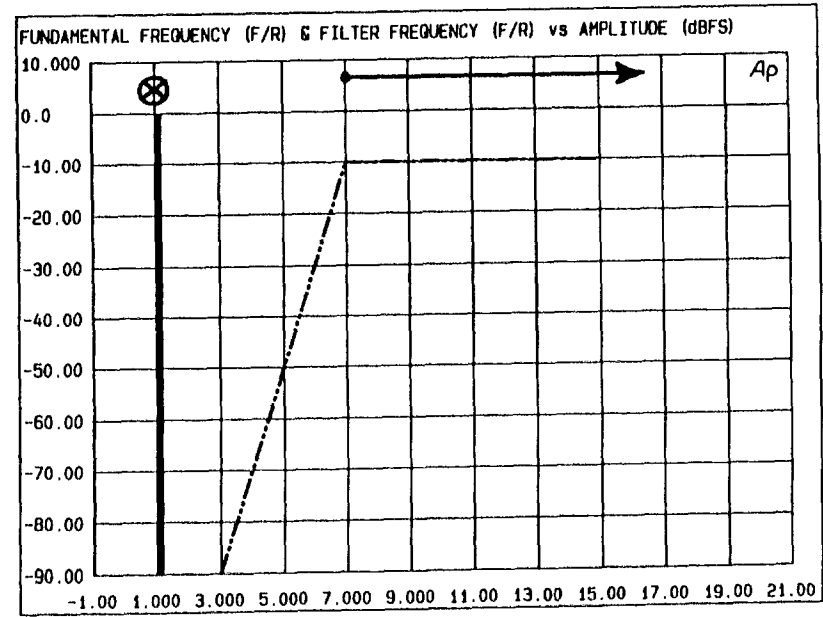

Figure 6: See Section 6.1

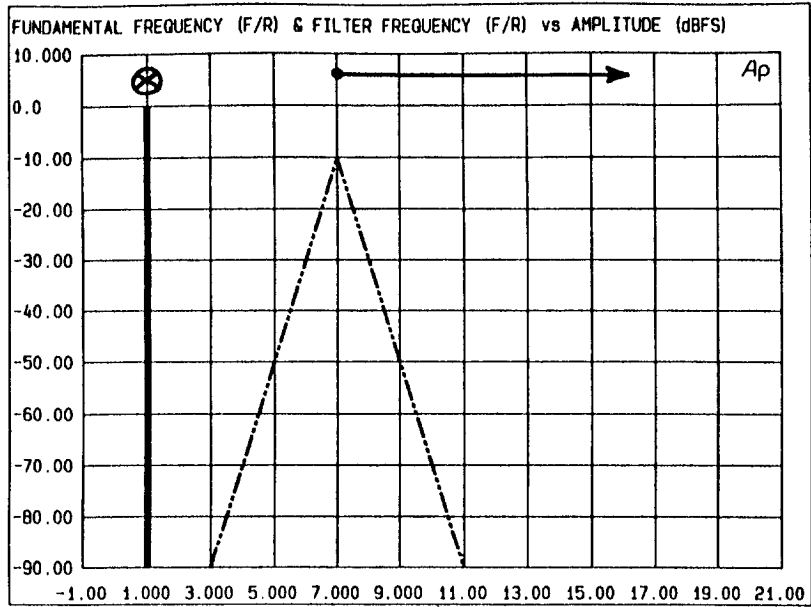

Figure 7: See Section 6.1

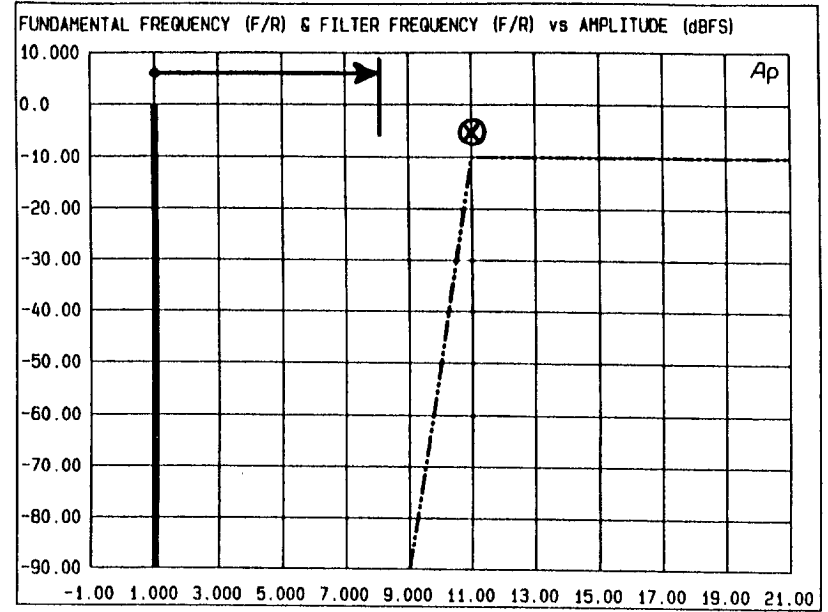

Figure 9: See Section 6.1

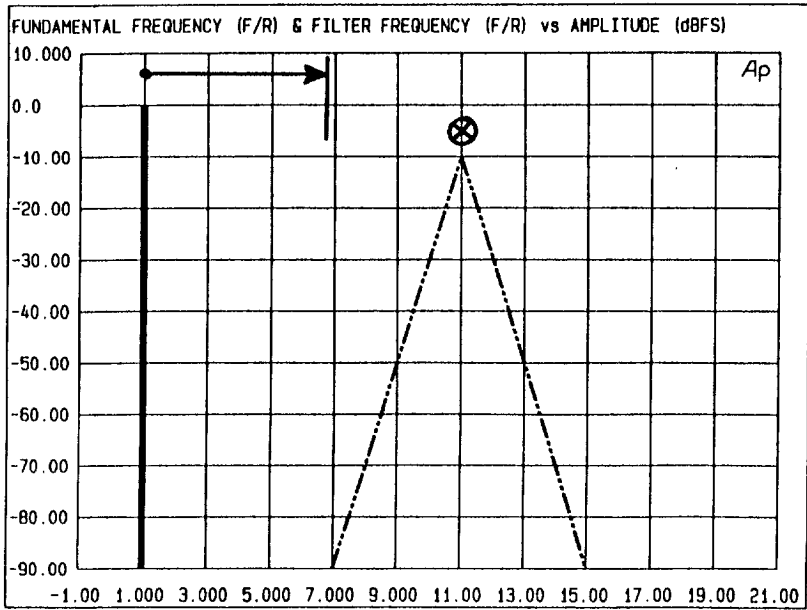

Figure 8: See Section 6.1

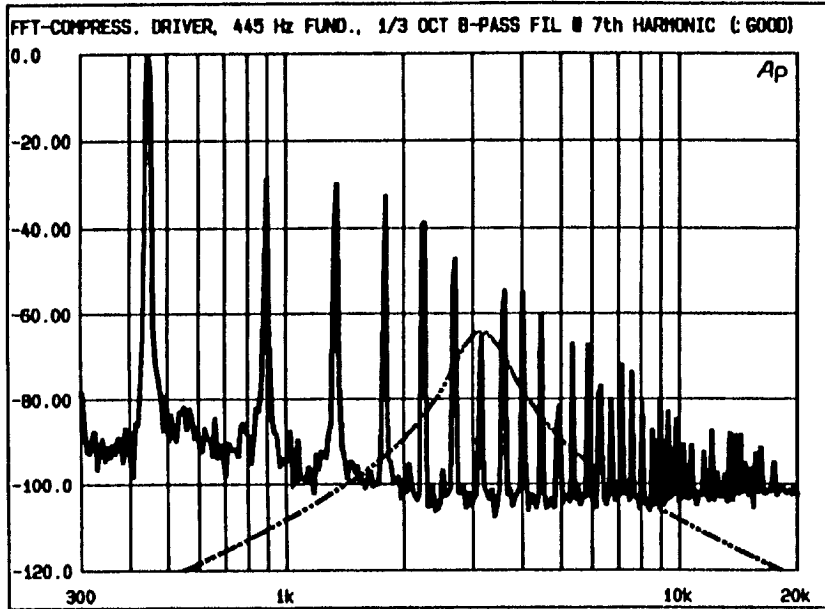

Figure 10: See Section 6.4

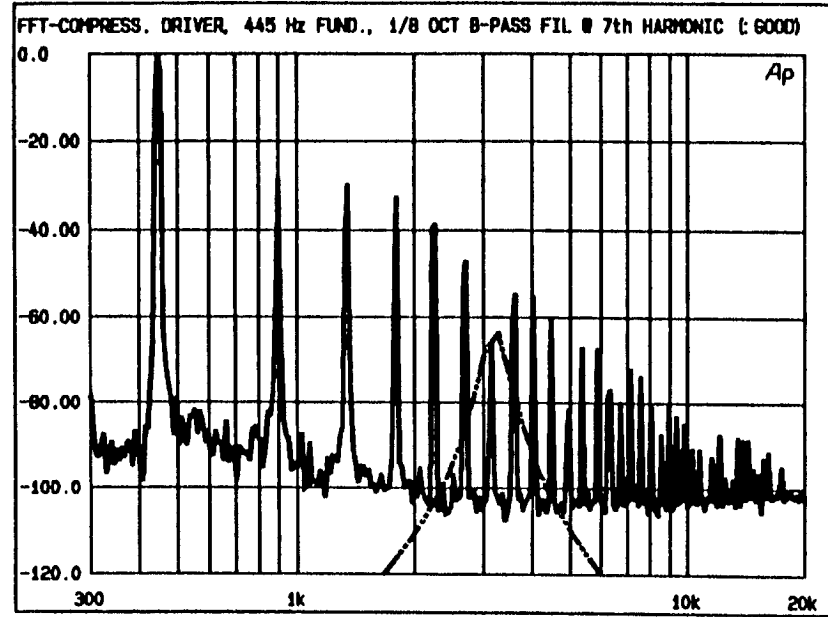

Figure 12: See Section 6.4

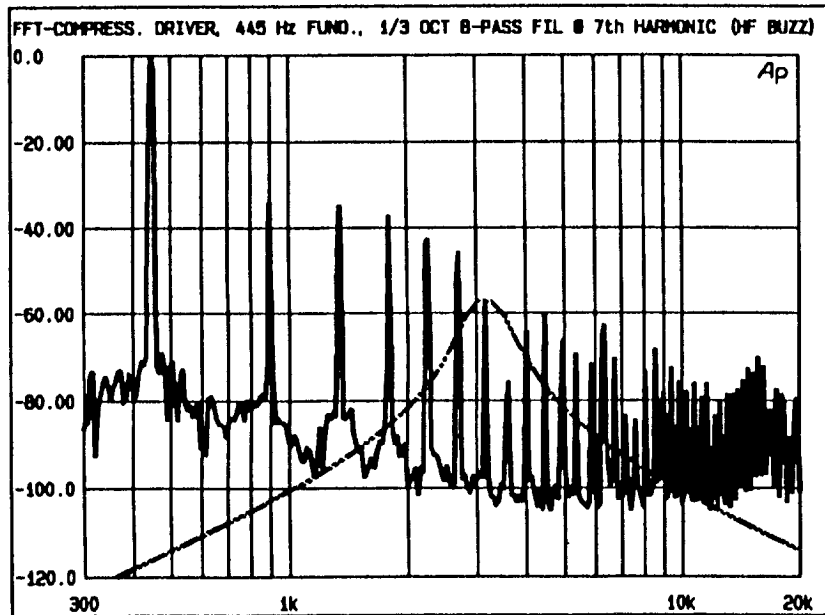

Figure 11: See Section 6.4

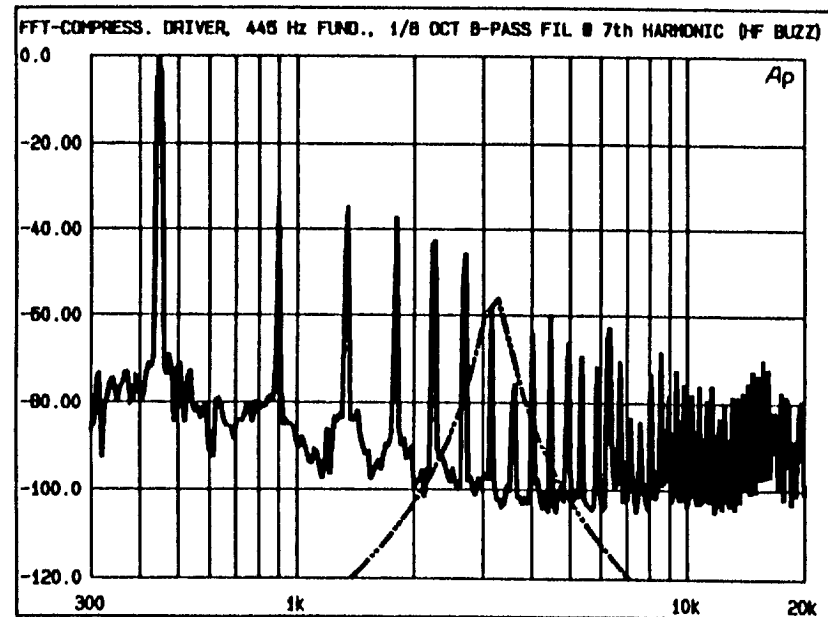

Figure 13: See Section 6.4

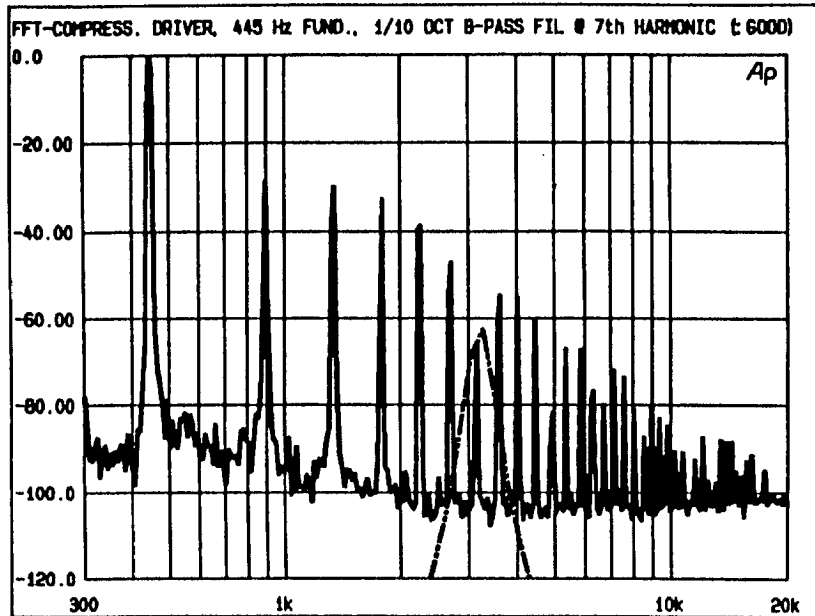

Figure 14: See Section 6.4, 6.5

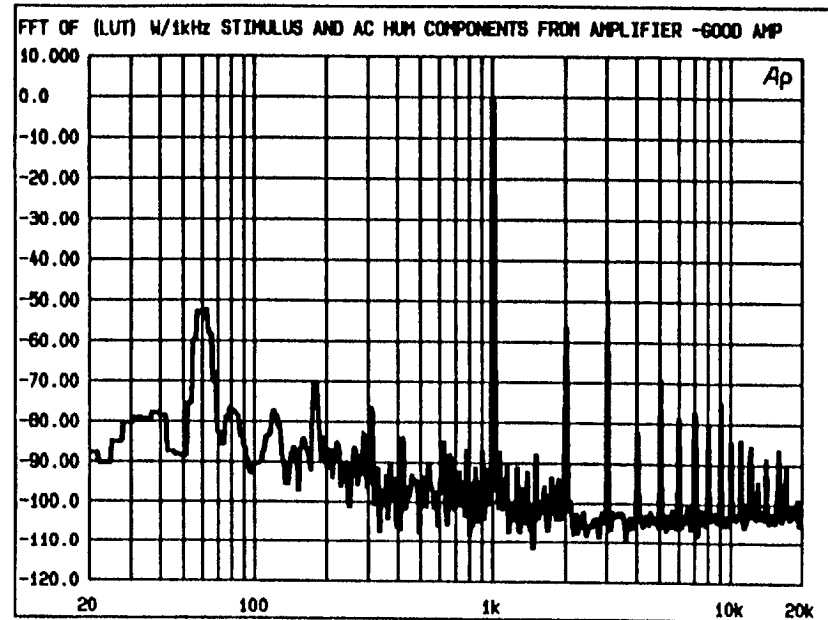

Figure 16: See Section 6.9, 10.10.4

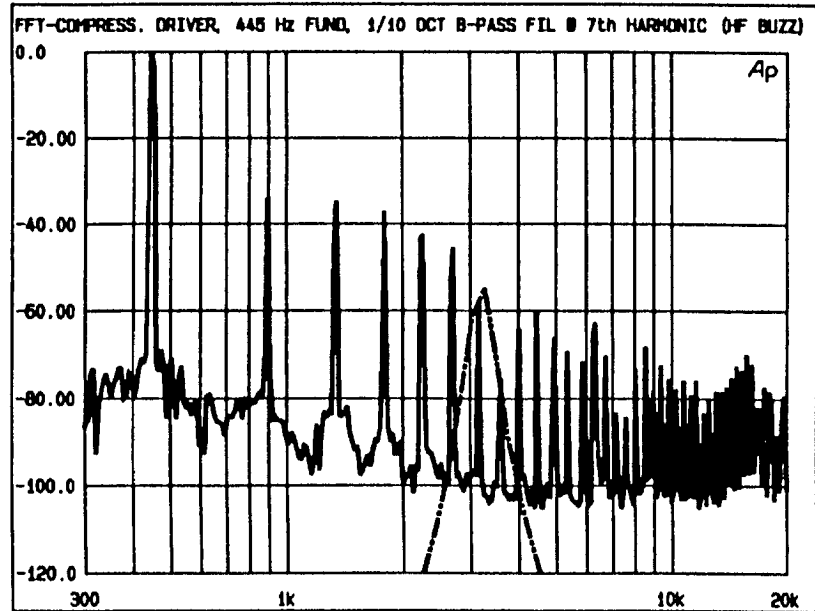

Figure 15: See Section 6.4, 6.5, 6.12

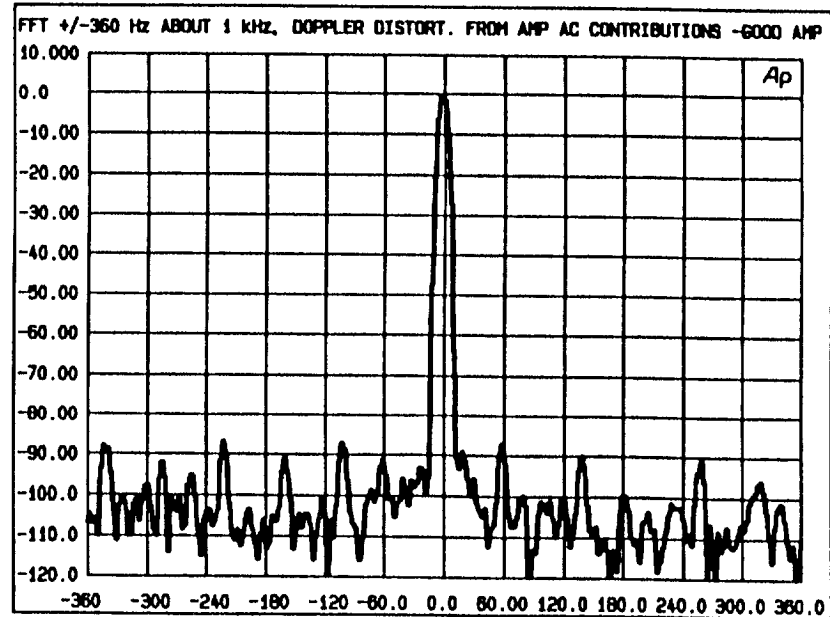

Figure 17: See Section 6.9, 10.10.4

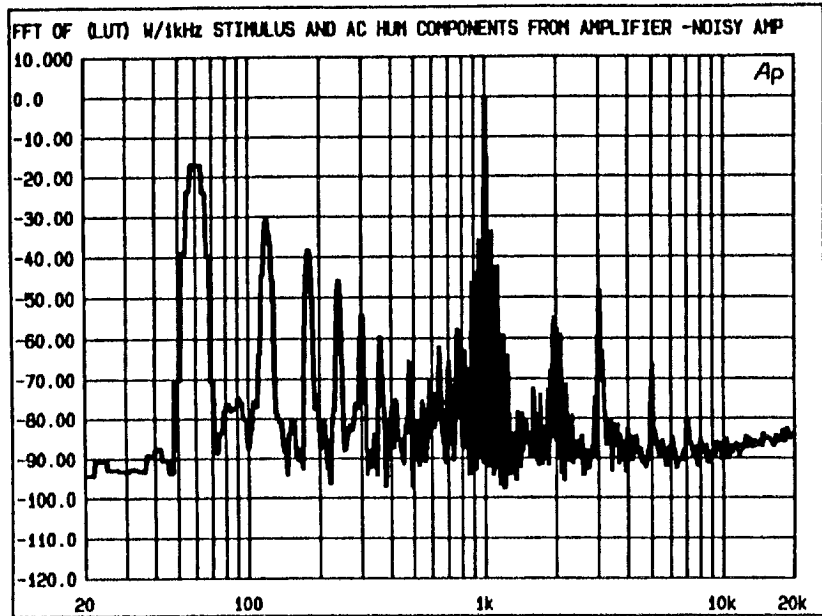

Figure 18: See Section 6.9

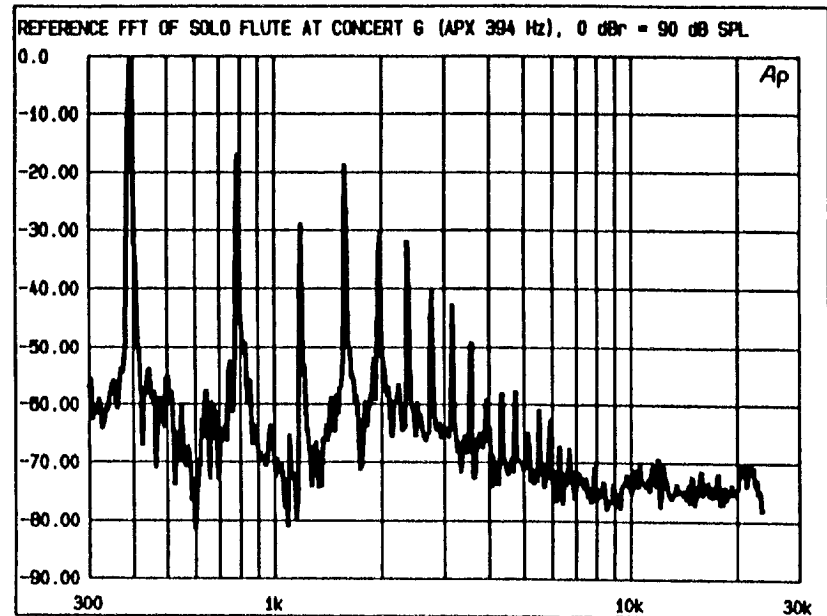

Figure 20: See Section 8.3, 8.4

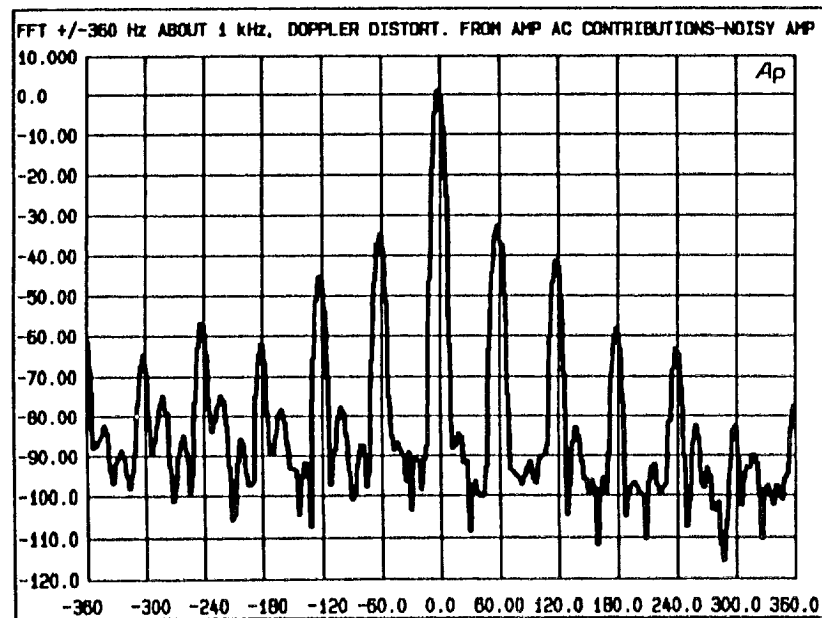

Figure 19: See Section 6.9

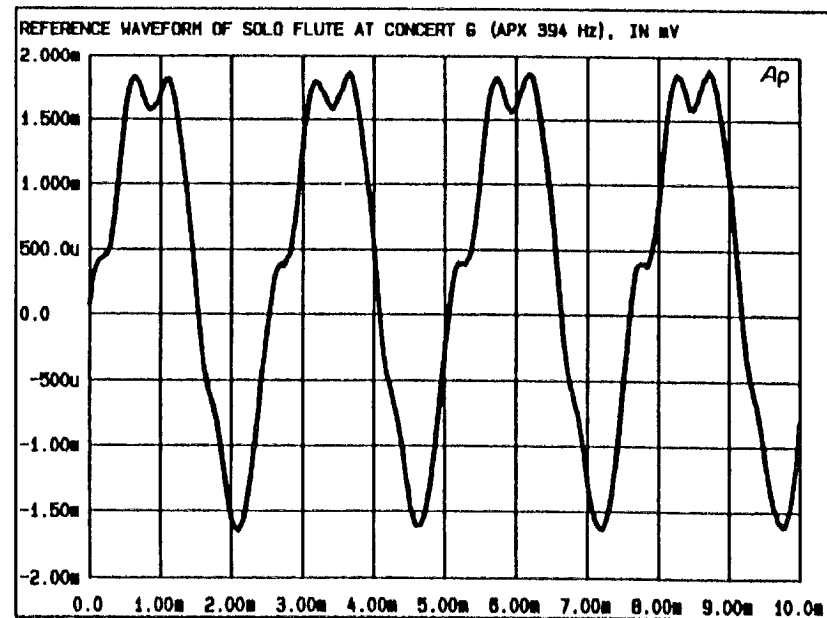

Figure 21: See Section 8.3

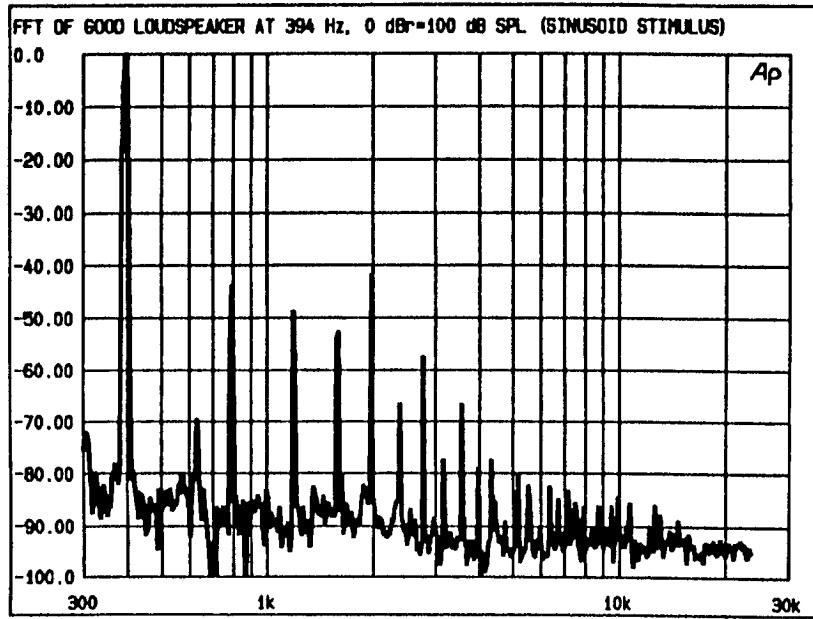

Figure 22: See Section 8.3, 8.4

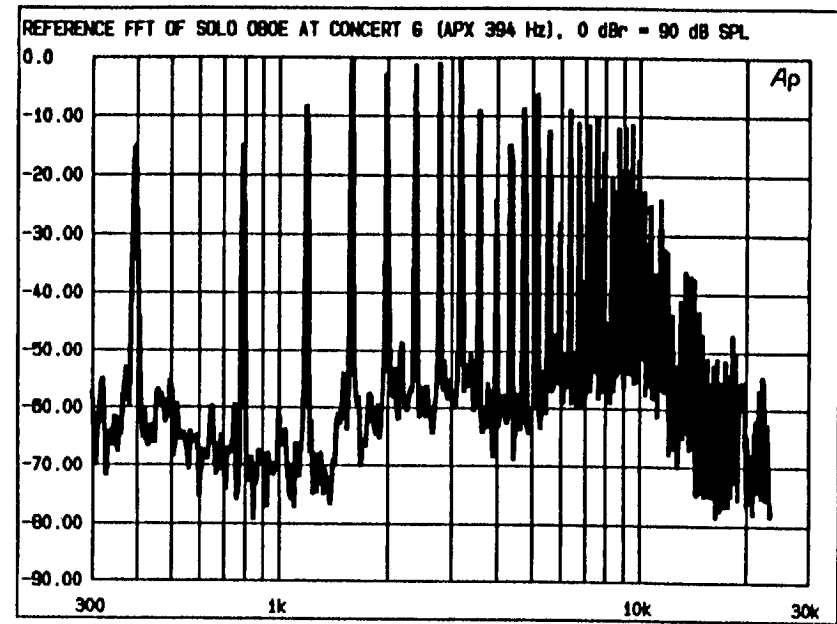

Figure 24: See Section 8.3, 8.4

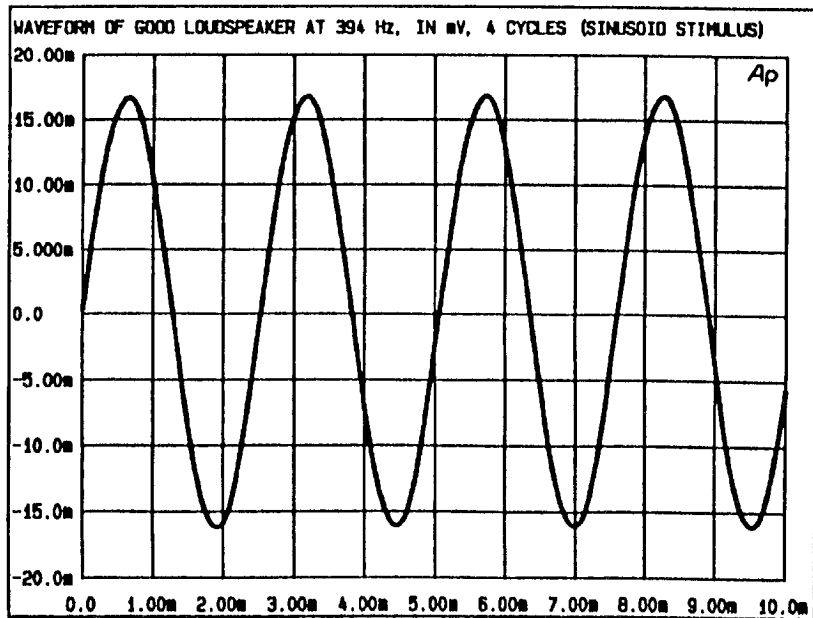

Figure 23: See Section 8.3

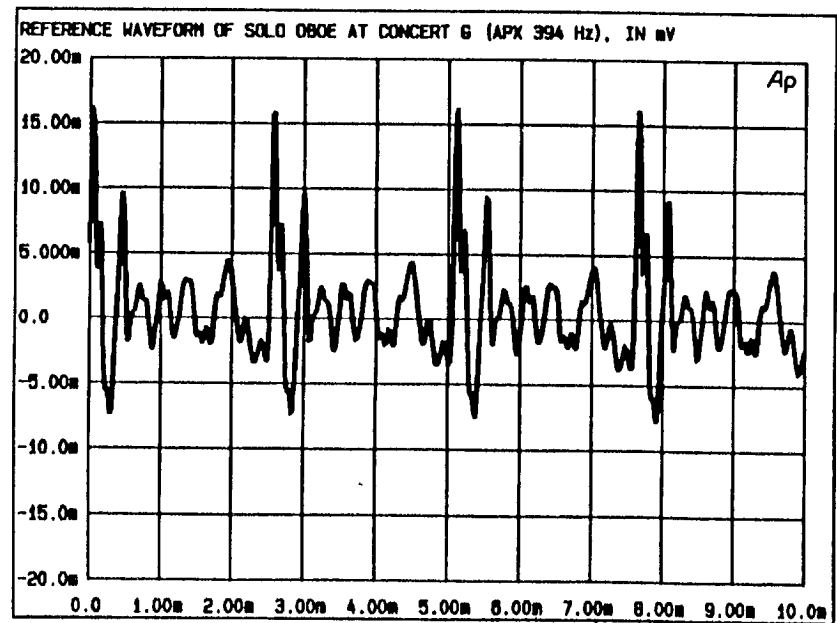

Figure 25: See Section 8.3, 8.4

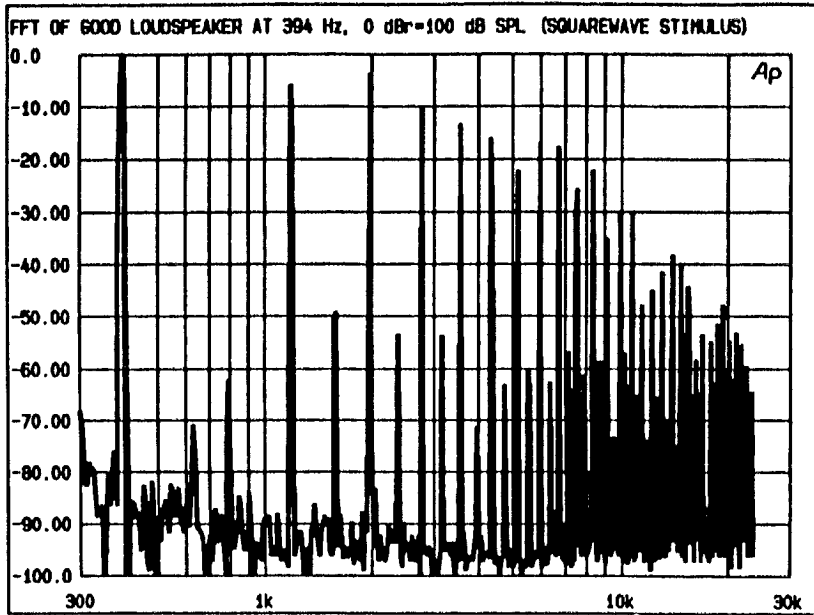

Figure 26: See Section 8.3, 8.4,

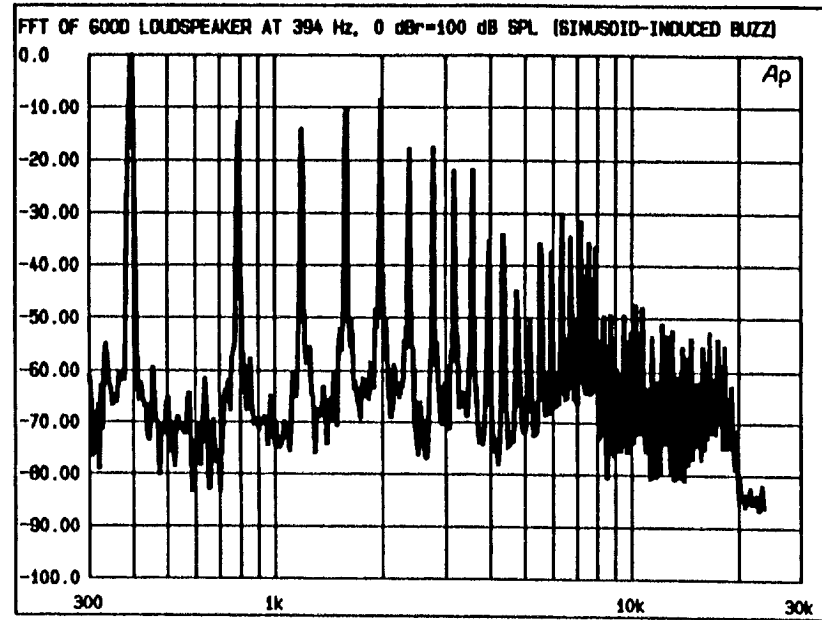

Figure 28: See Section 8.3, 8.4,

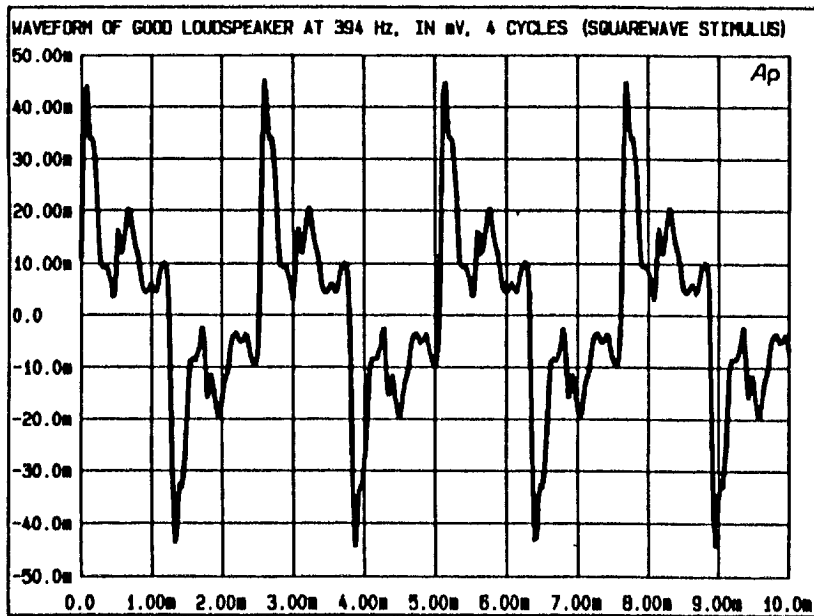

Figure 27: See Section 8.3, 8.4

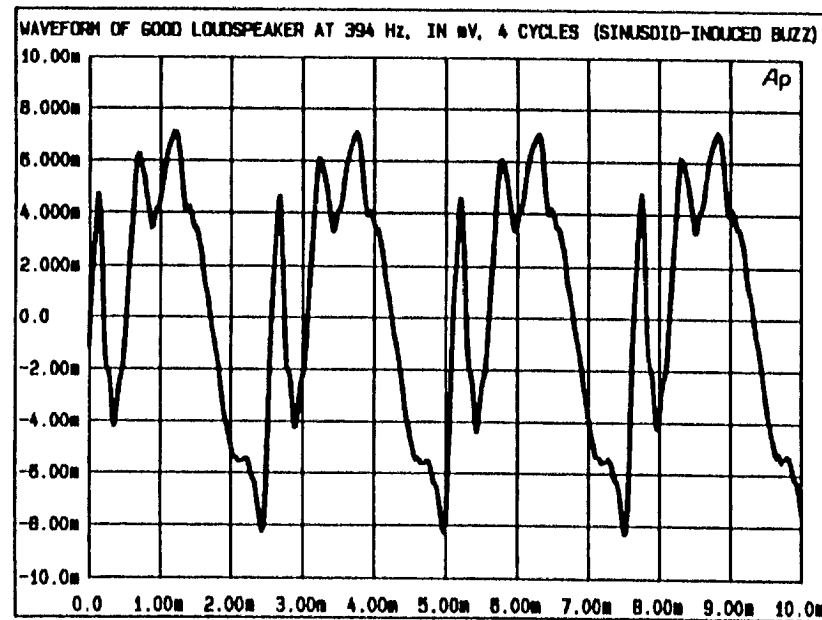

Figure 29: See Section 8.3, 8.4

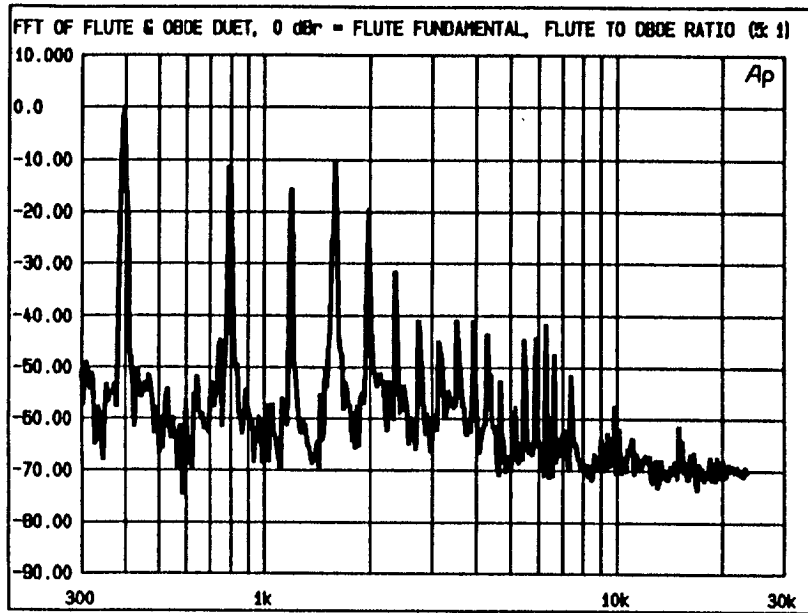

Figure 30: See Section 8.5

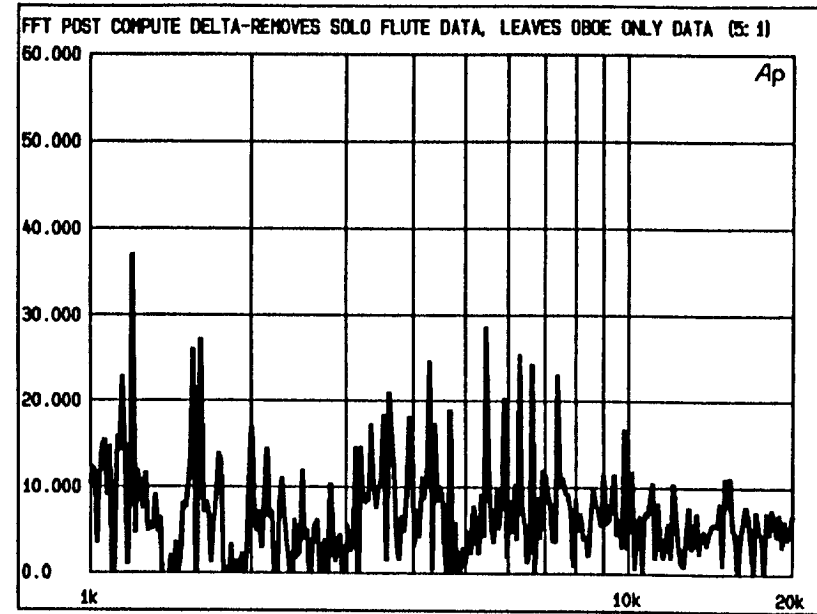

Figure 31: See Section 8.5

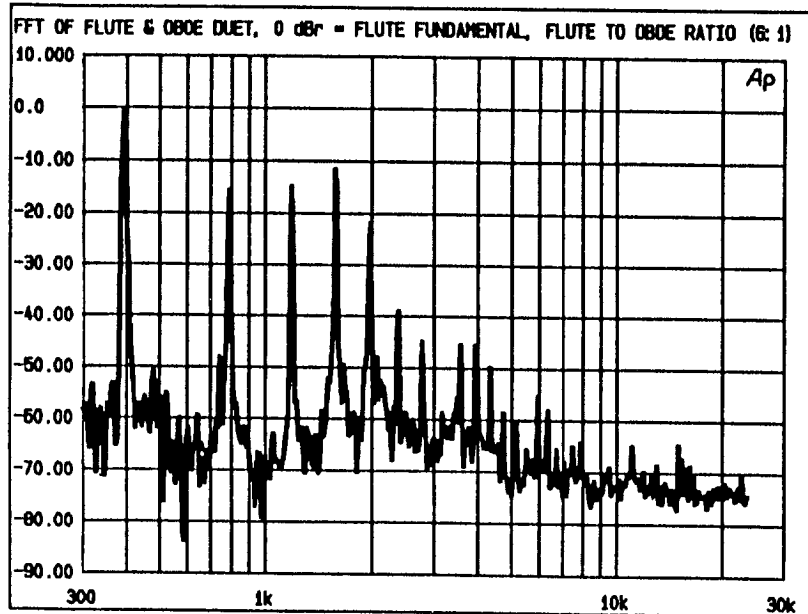

Figure 32: See Section 8.5

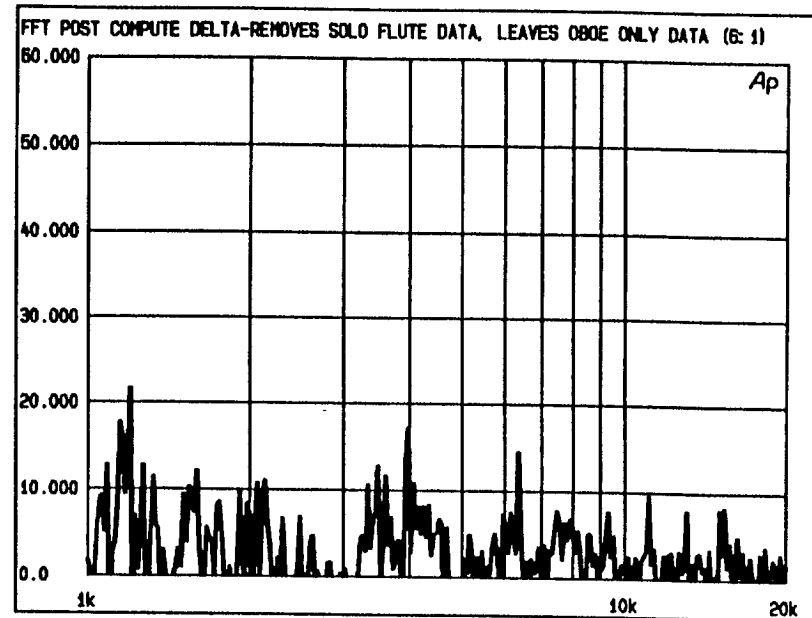

Figure 33: See Section 8.5

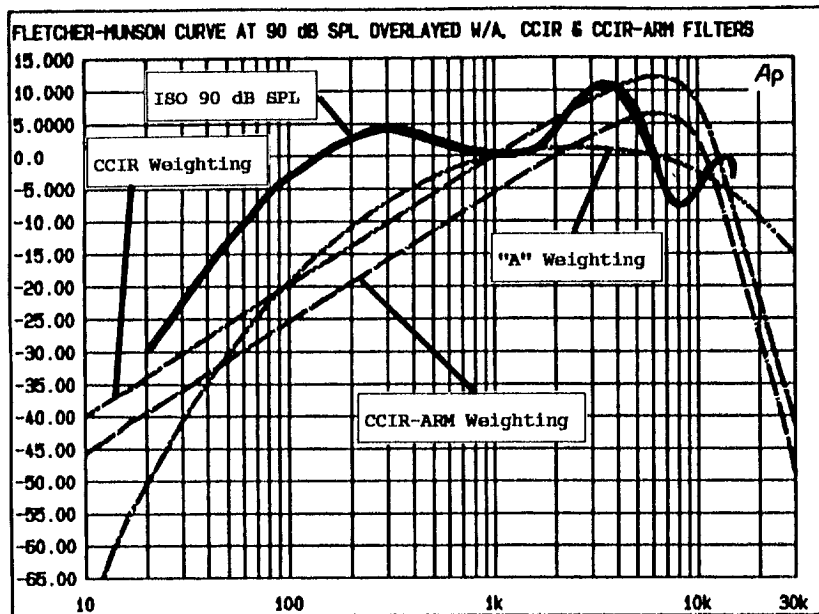

Figure 34: See Section 8.7

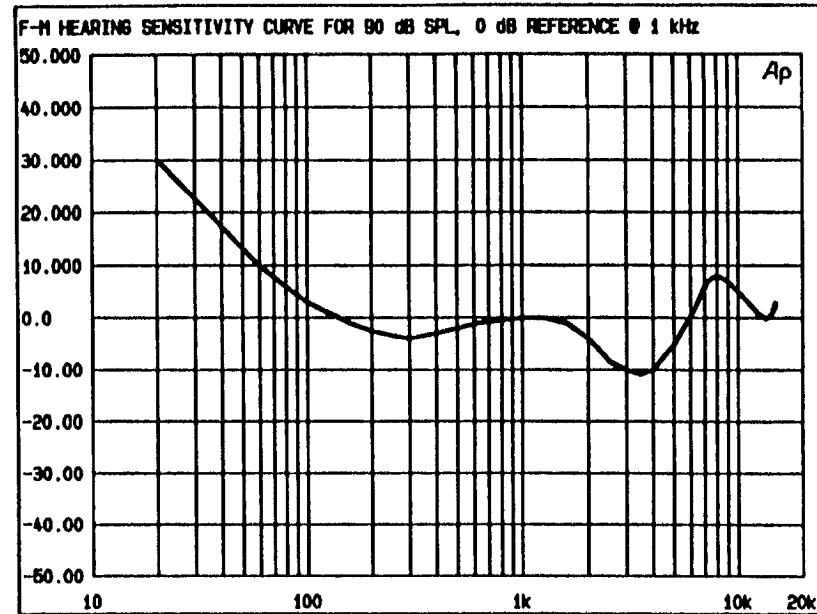

Figure 36: See Section 8.6, 8.8

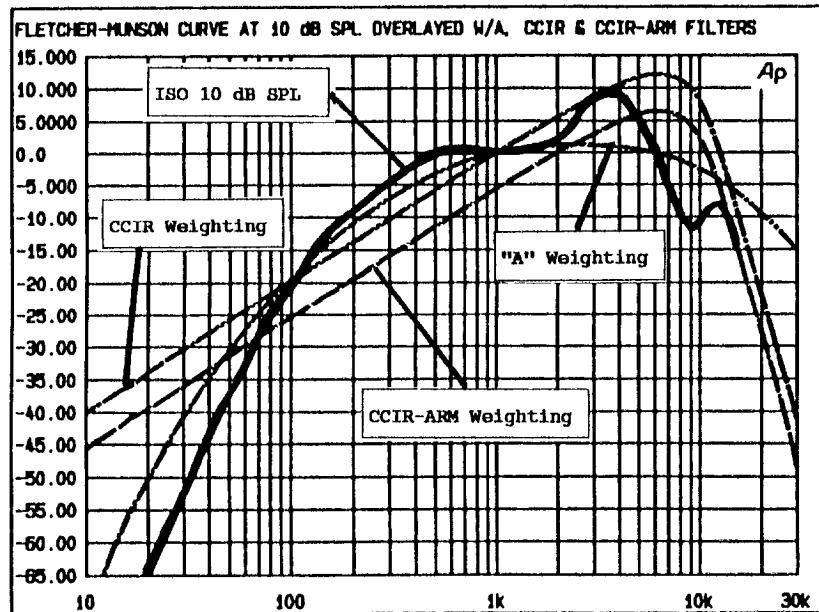

Figure 35: See Section 8.7

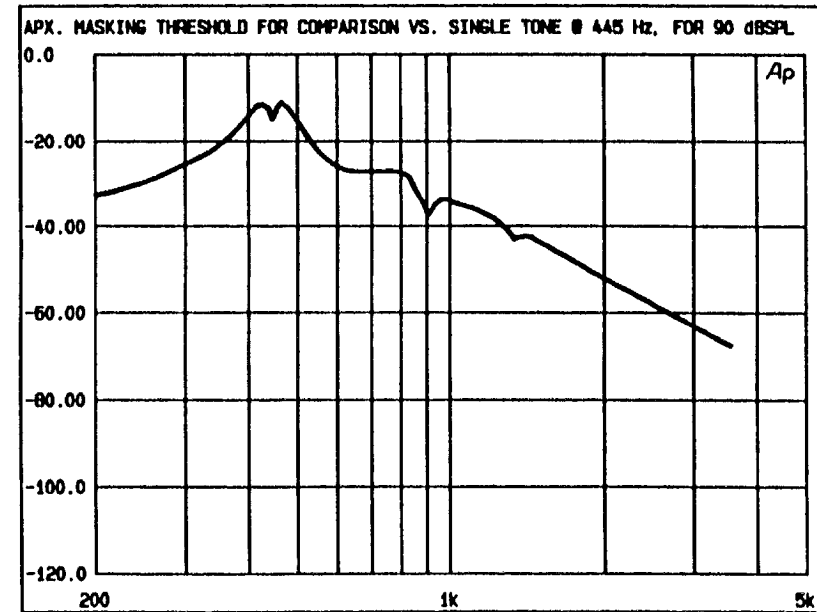

Figure 37: See Section 8.6, 8.8, 8.10

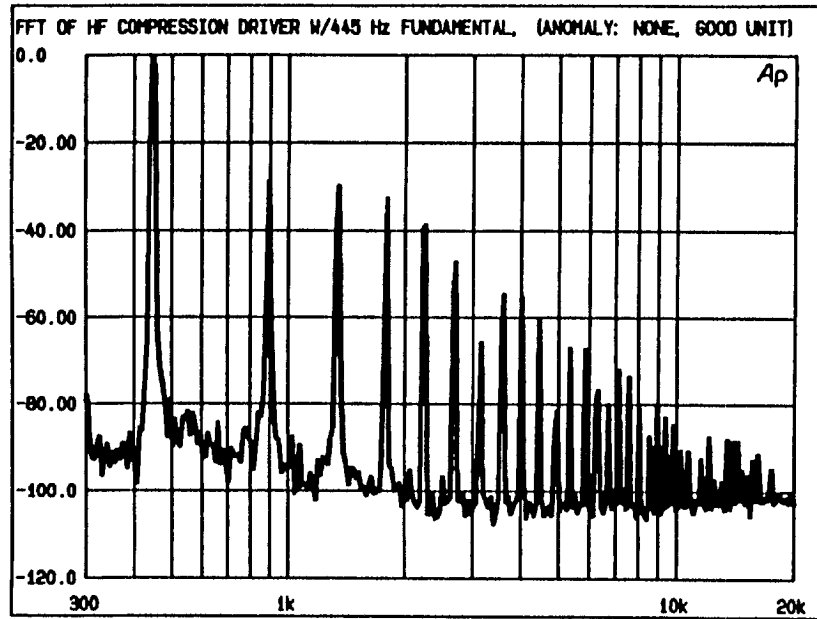

Figure 38: See Section 8.8

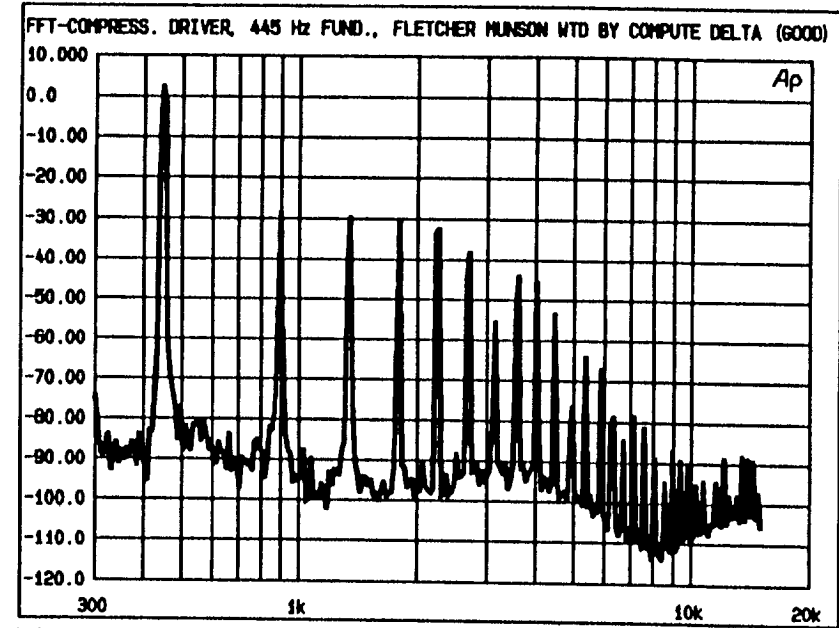

Figure 40: See Section 8.9

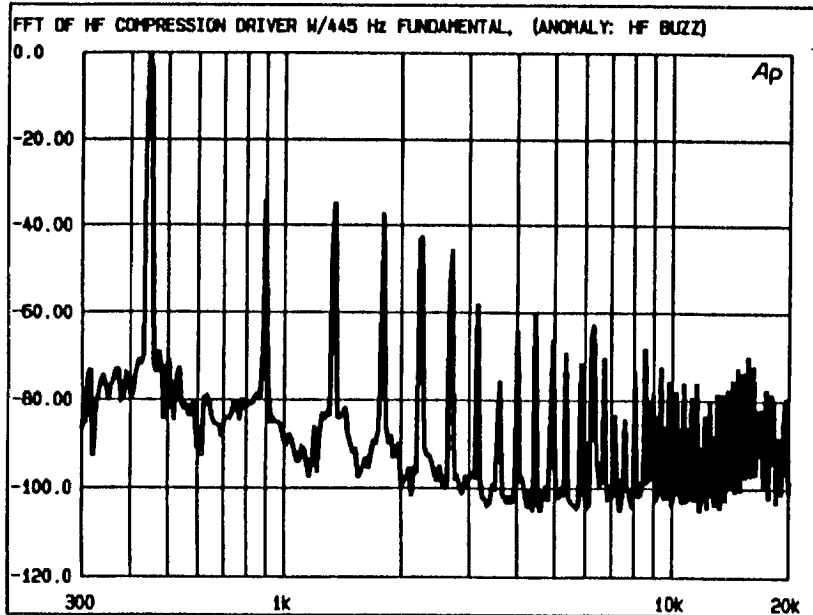

Figure 39: See Section 8.8

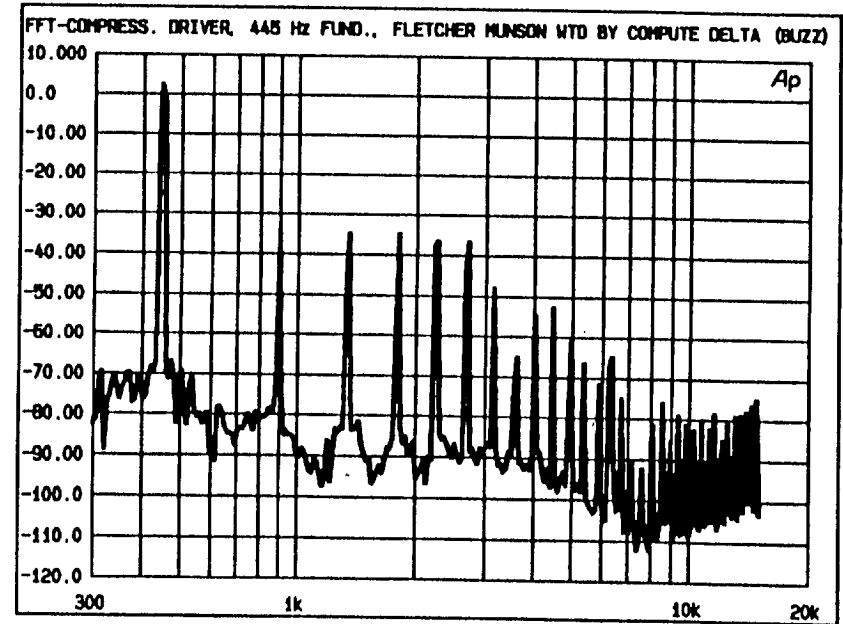

Figure 41: See Section 8.9

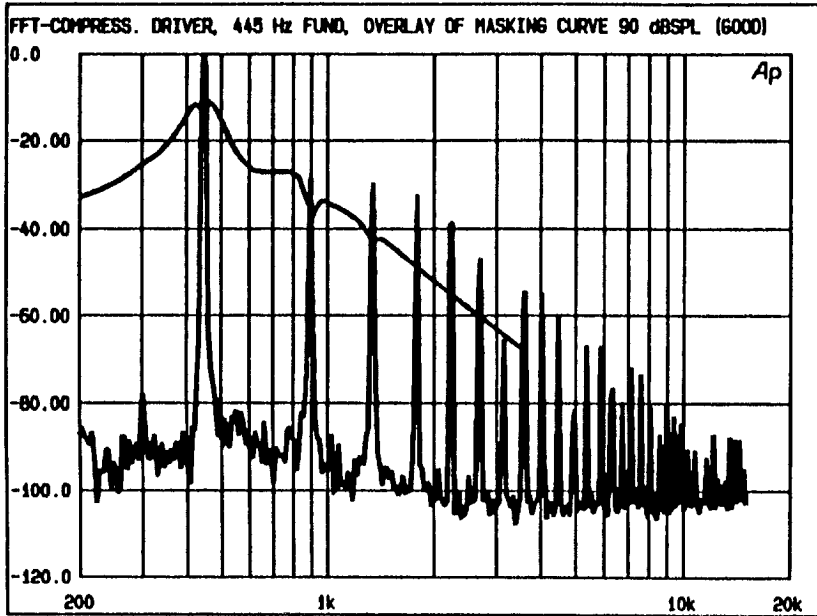

Figure 42: See Section 8.10, 8.11

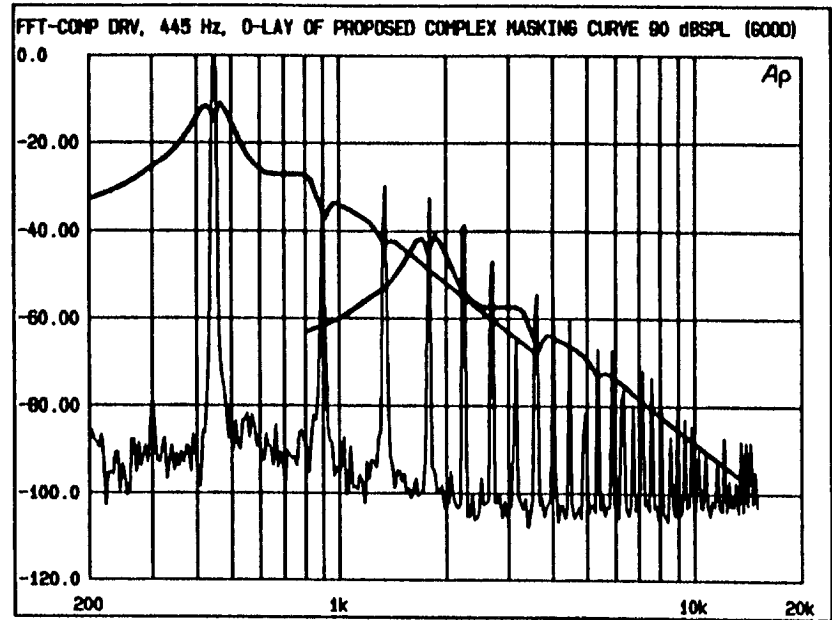

Figure 44: See Section 8.11

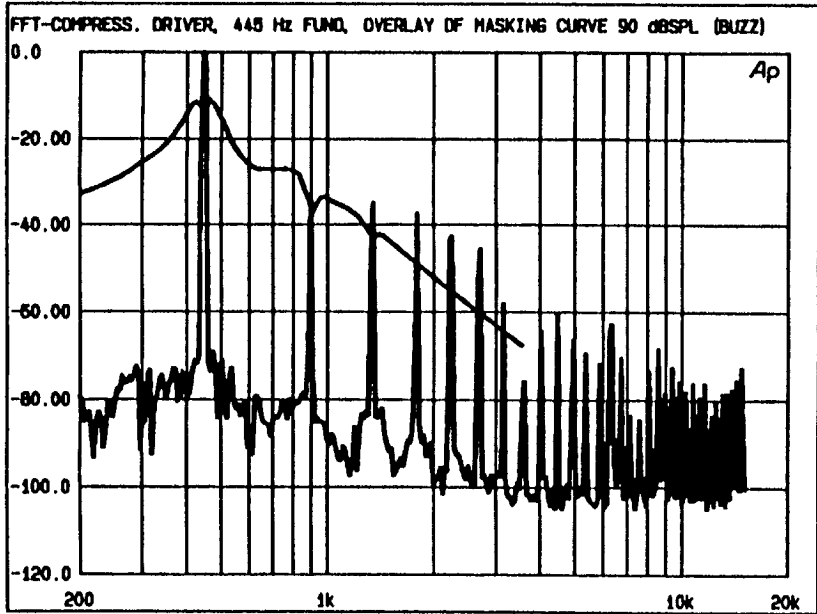

Figure 43: See Section 8.10

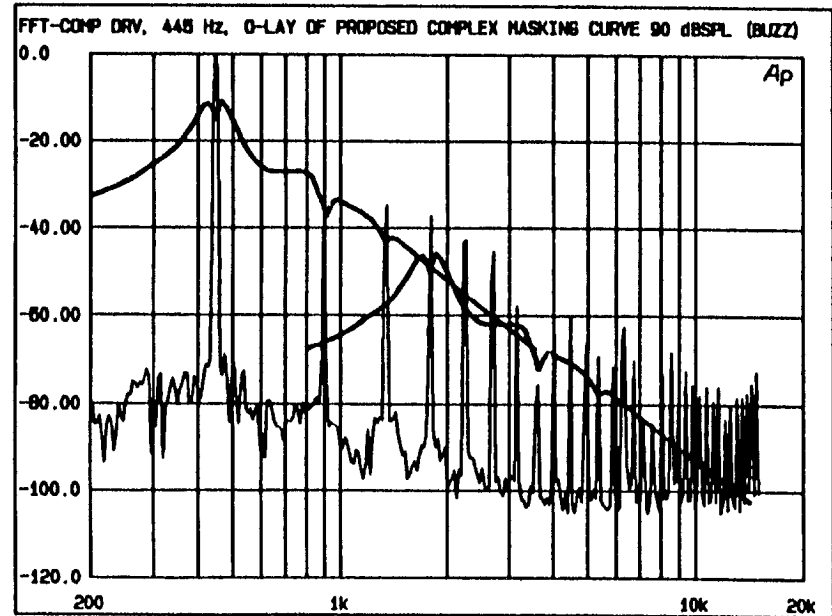

Figure 45: See Section 8.11

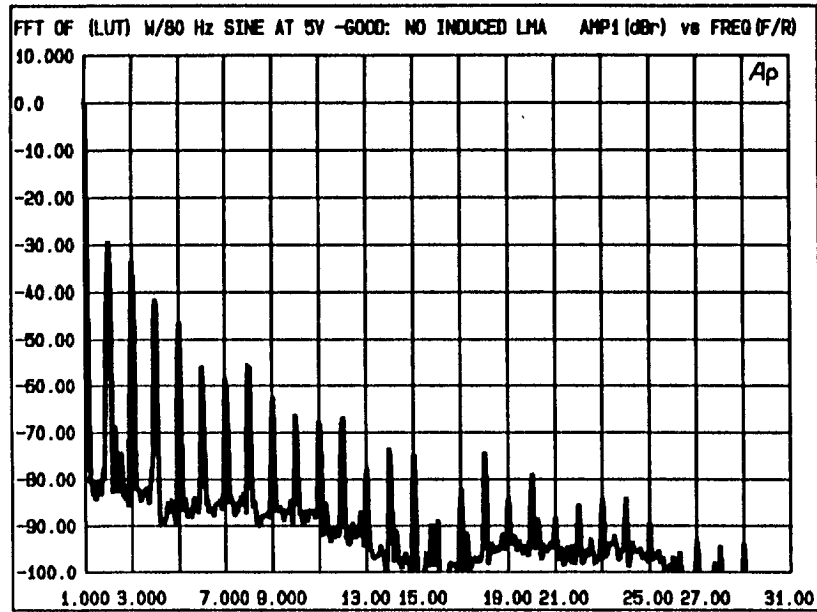

Figure 46: See Section 9.5, 9.6, 9.8, 9.11, 9.17

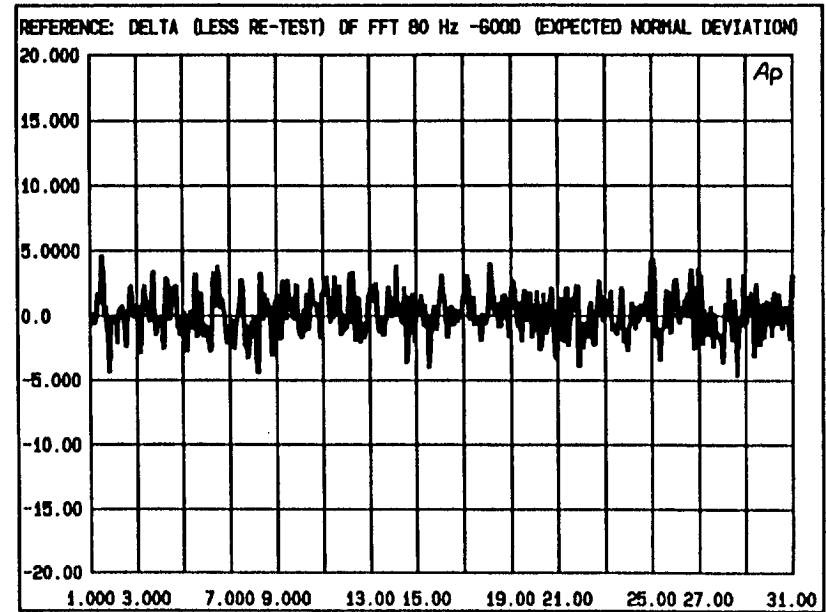

Figure 47: See Section 9.5, 9.8, 9.17

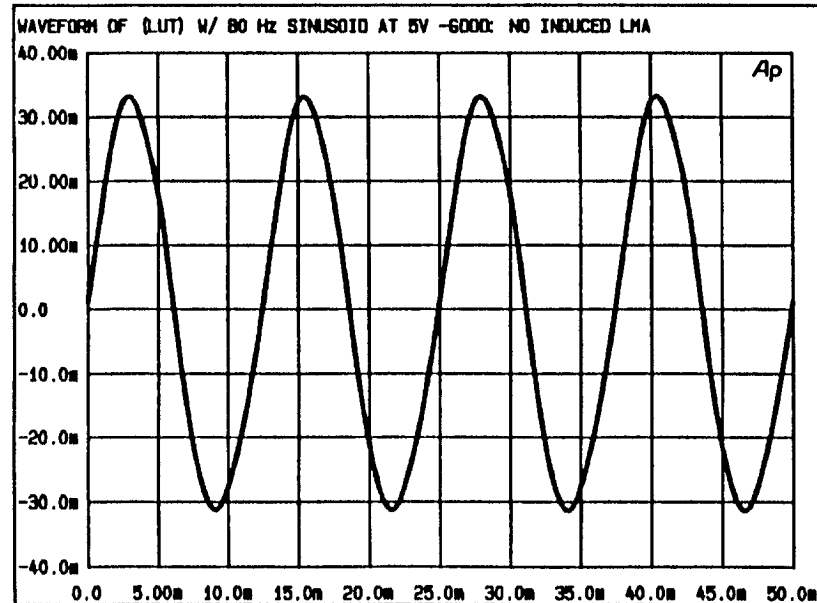

Figure 48: See Section 9.5, 9.13, 9.17

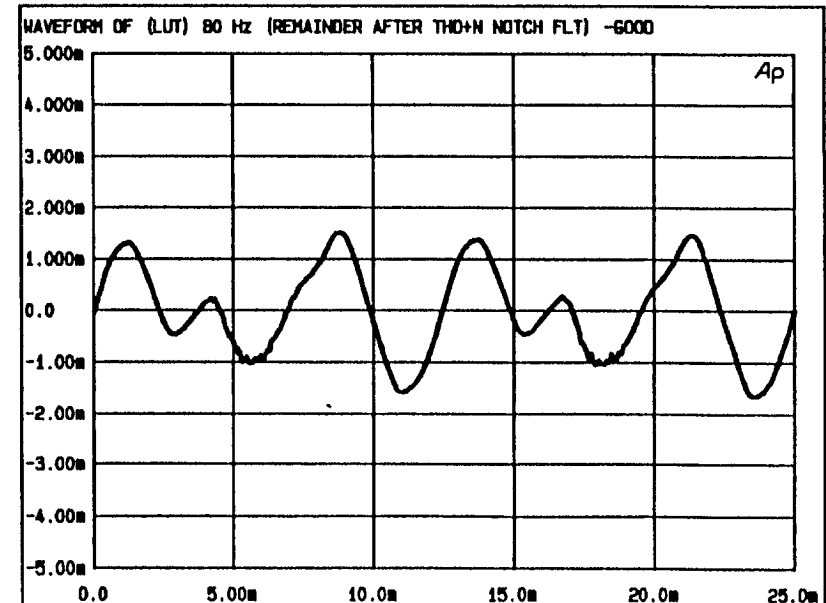

Figure 49: See Section 9.5, 9.14, 9.15, 9.17

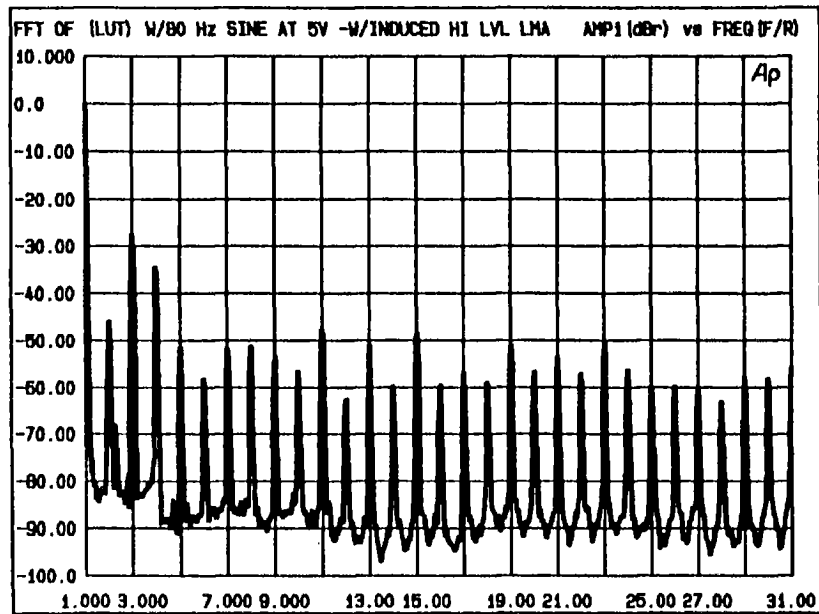

Figure 50: See Section 9.7, 9.8, 9.11, 9.16

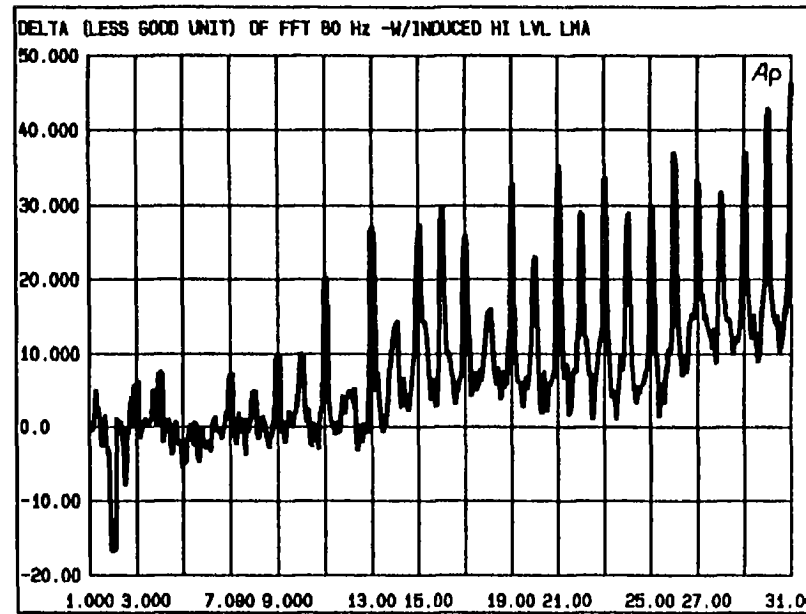

Figure 51: See Section 9.7, 9.8, 9.16

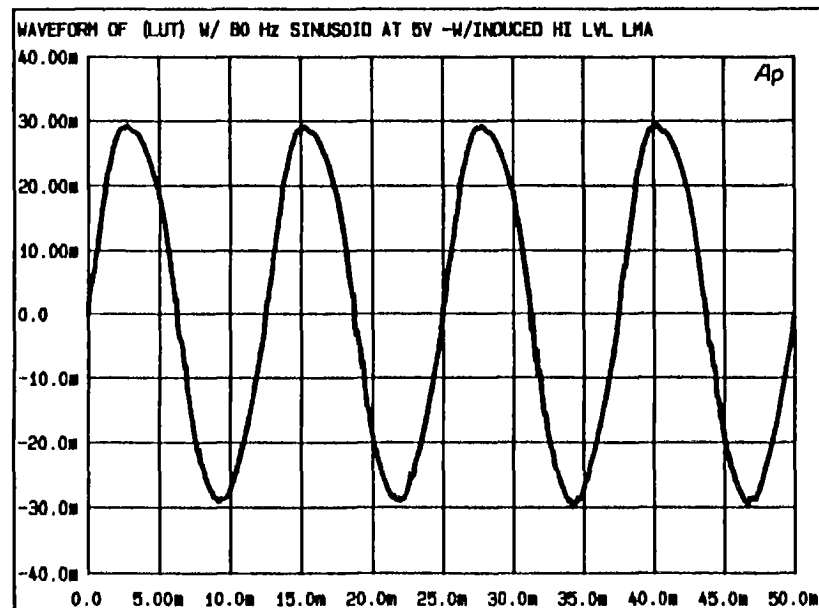

Figure 52: See Section 9.7, 9.13, 9.16

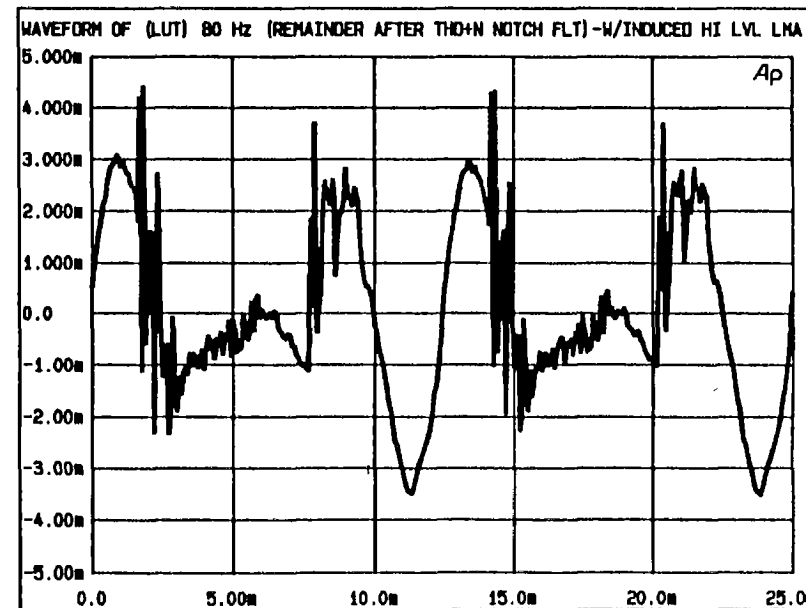

Figure 53: See Section 9.7, 9.14, 9.15, 9.16

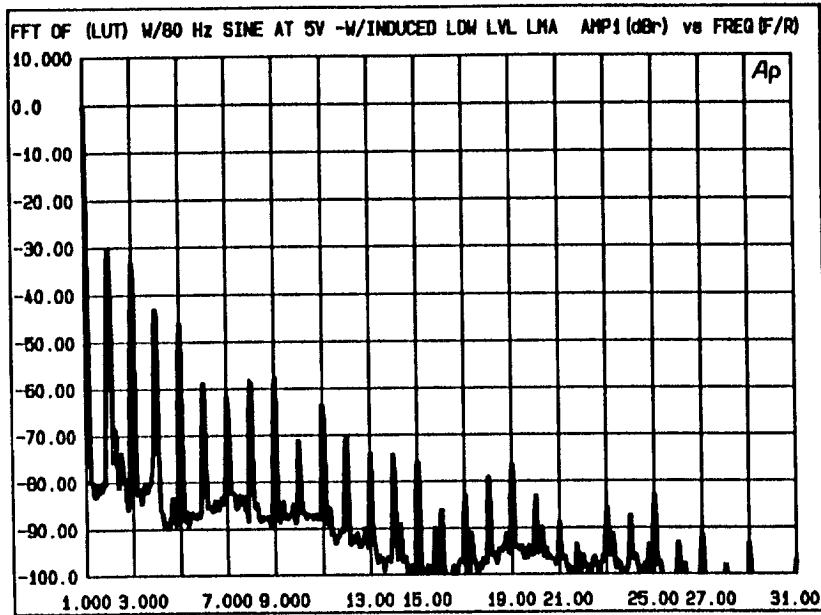

Figure 54: See Section 9.17

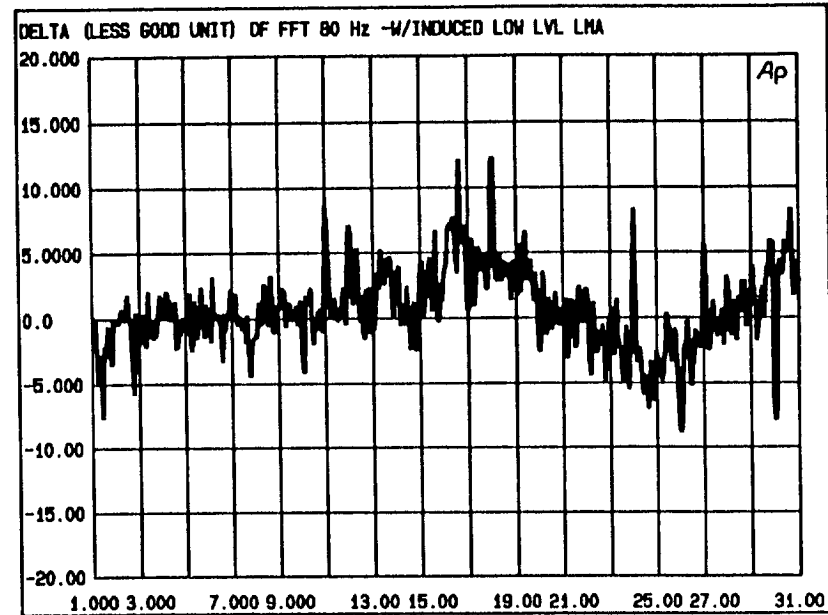

Figure 55: See Section 9.17, 9.19

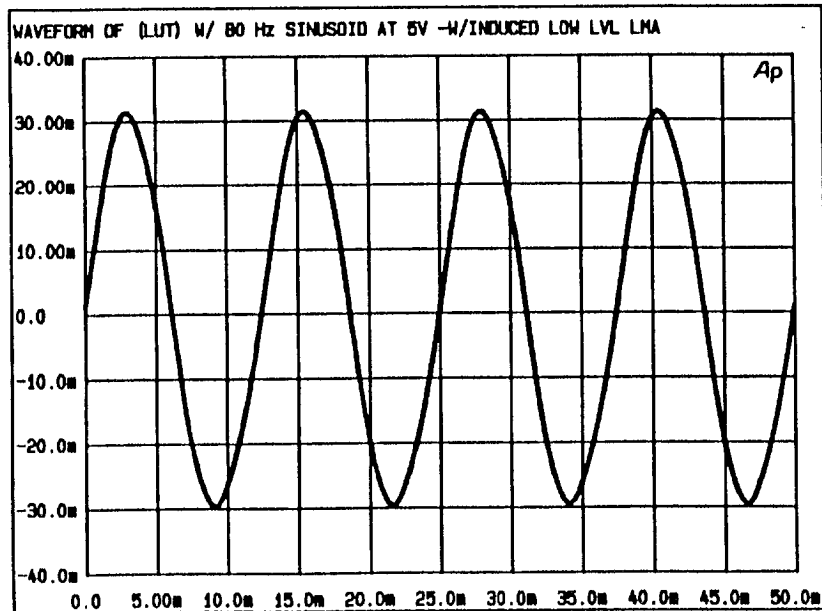

Figure 56: See Section 9.17

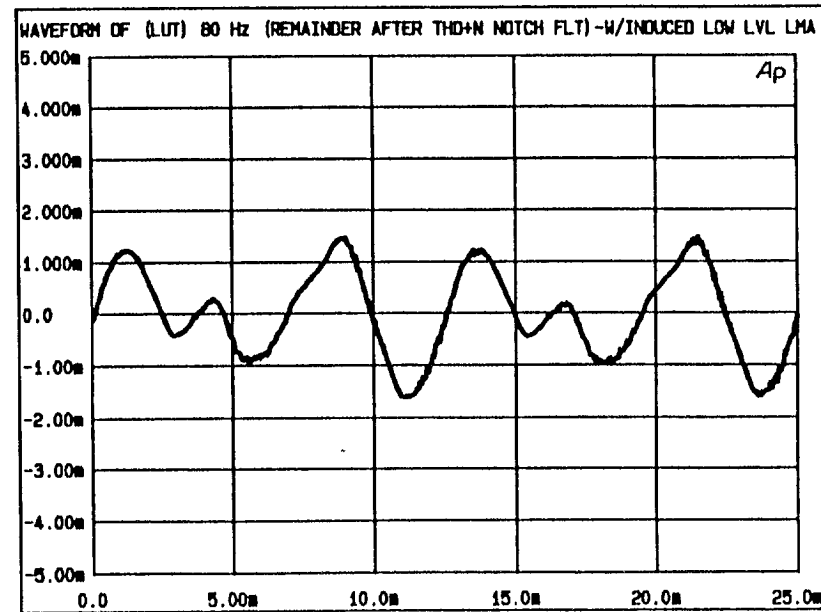

Figure 57: See Section 9.17

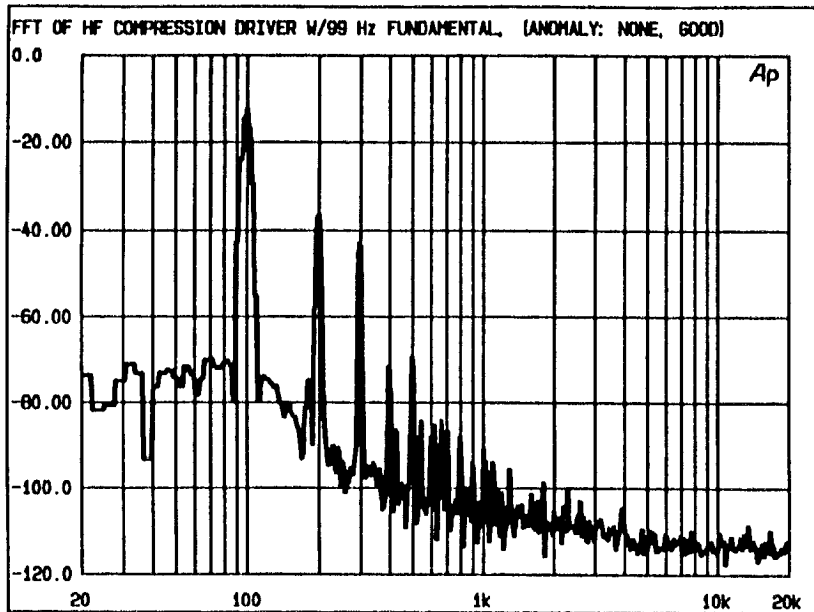

Figure 58: See Section 9.24, 9.26, 10.2

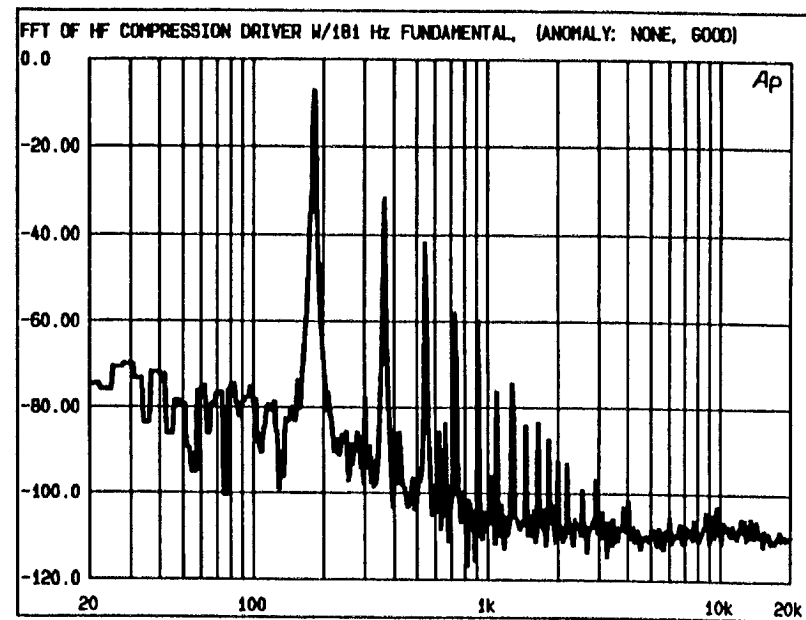

Figure 60: See Section 9.24, 9.26, 10.2

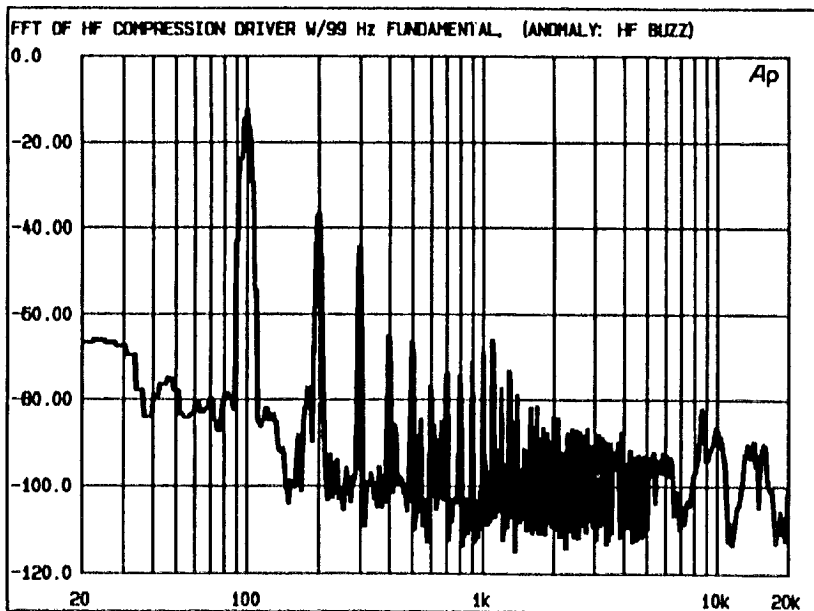

Figure 59: See Section 9.24, 9.26, 10.2



Figure 61: See Section 9.24, 9.26, 10.2

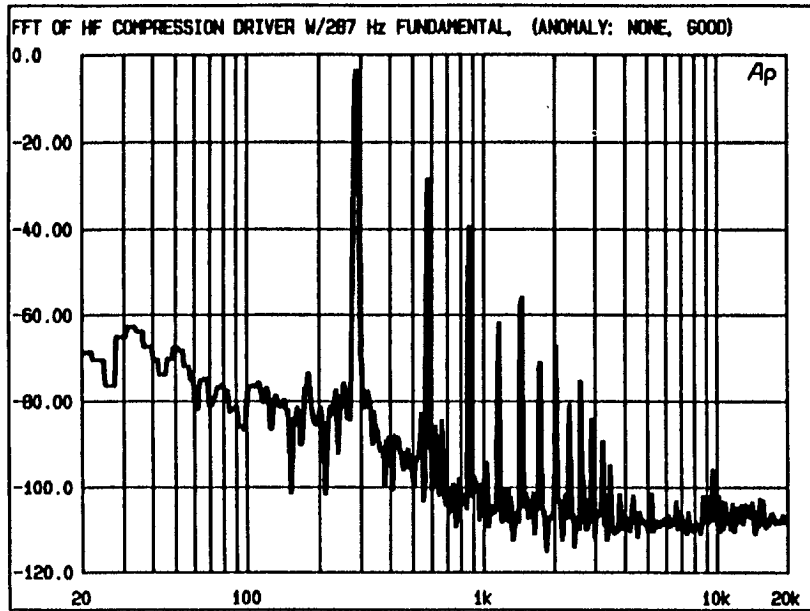

Figure 62: See Section 9.24, 9.26, 10.2

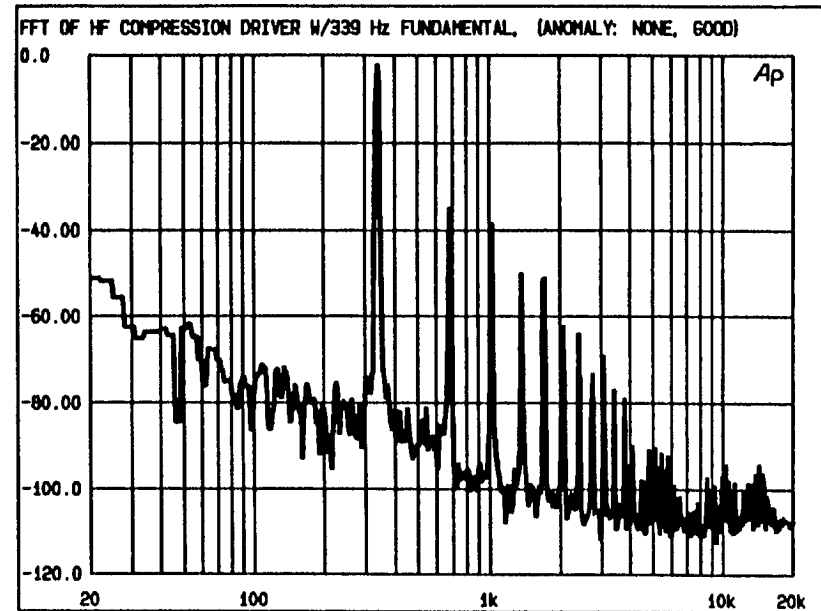

Figure 64: See Section 9.24, 9.26, 10.2

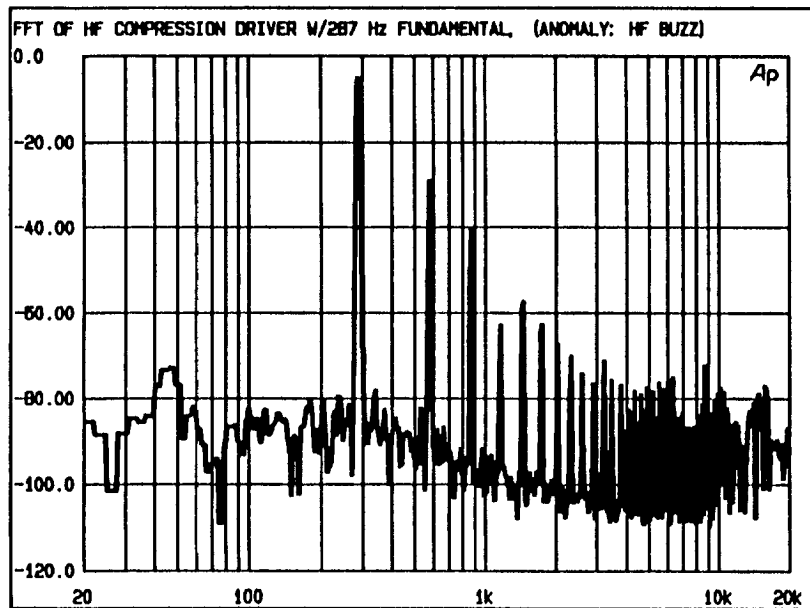

Figure 63: See Section 9.24, 9.26, 10.2

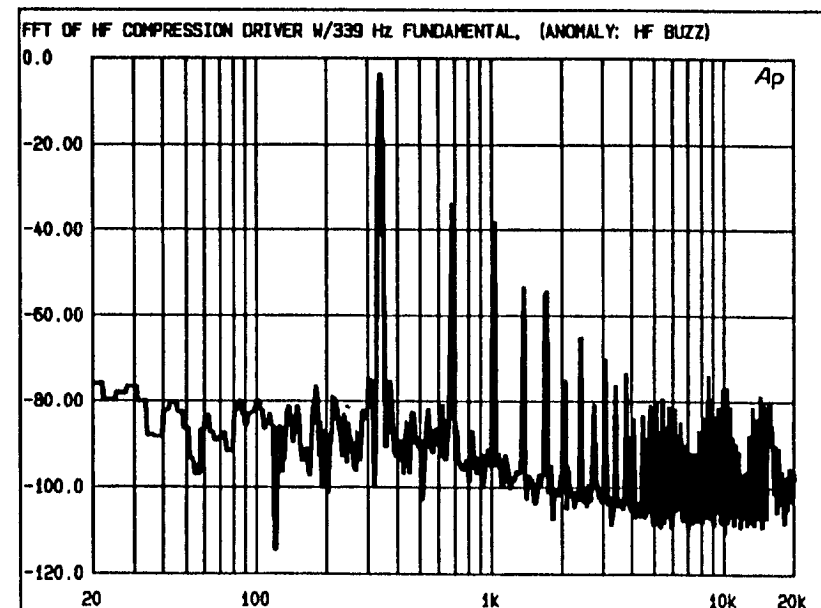

Figure 65: See Section 9.24, 9.26, 10.2

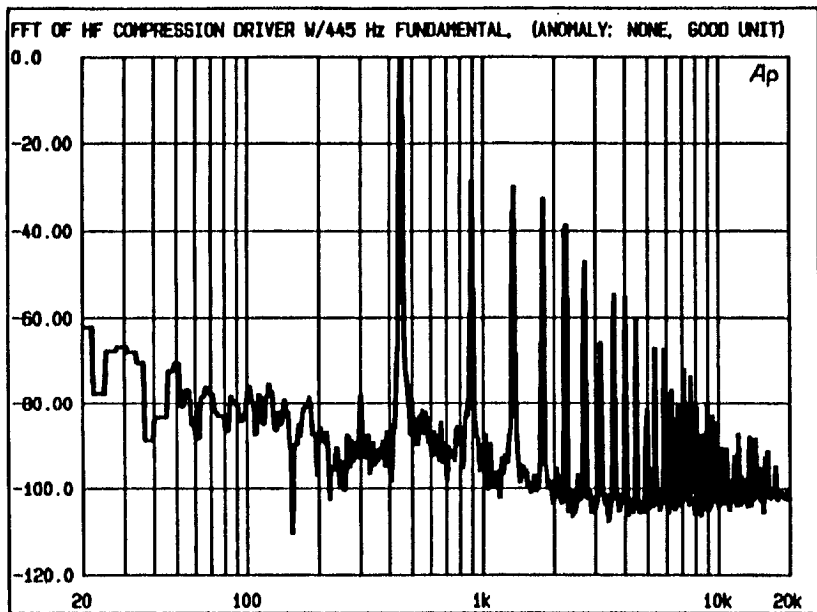

Figure 66: See Section 9.24, 9.26, 10.2

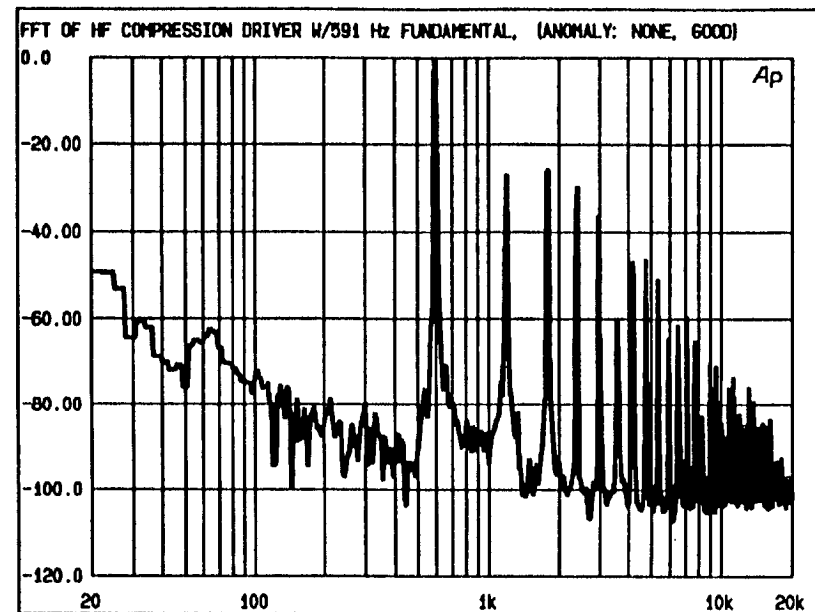

Figure 68: See Section 9.24, 9.26, 10.2

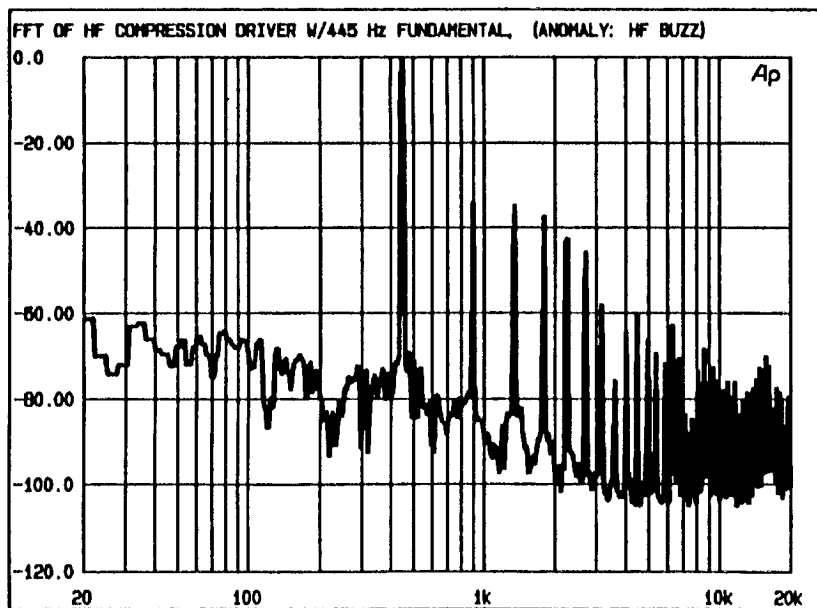

Figure 67: See Section 9.24, 9.26, 10.2

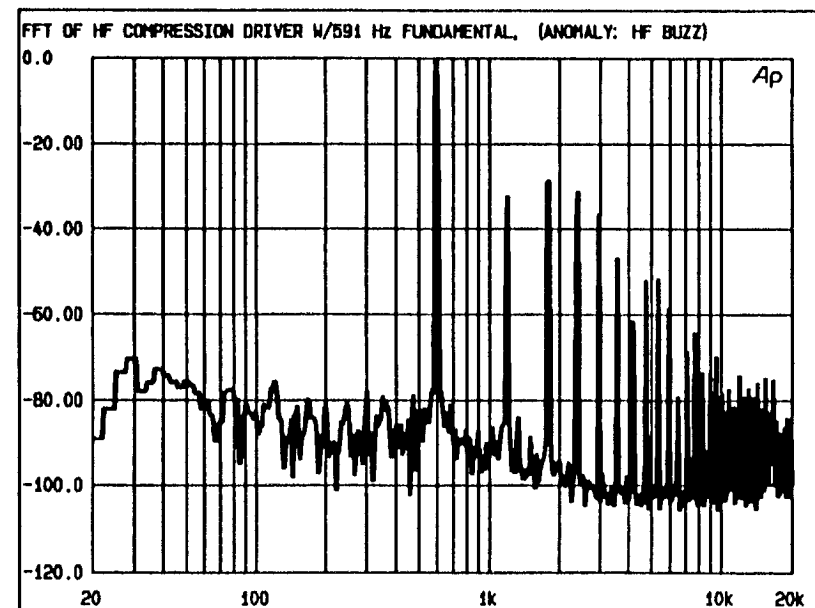

Figure 69: See Section 9.24, 9.26, 10.2

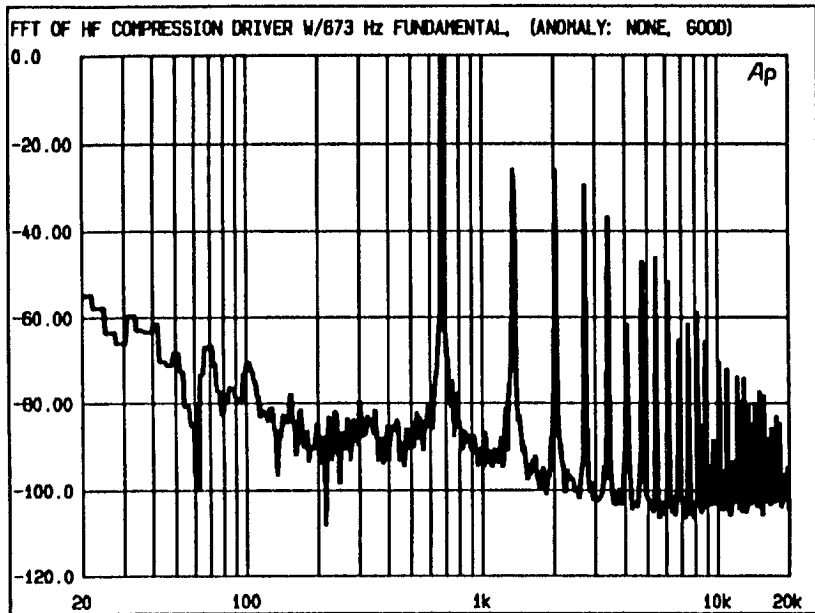

Figure 70: See Section 9.24, 9.26, 10.2

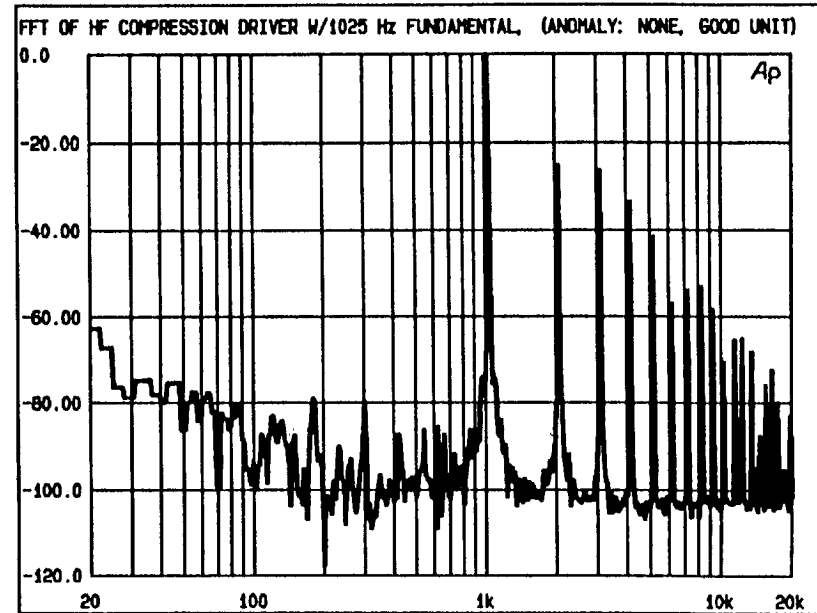

Figure 72: See Section 9.24, 9.26, 10.2

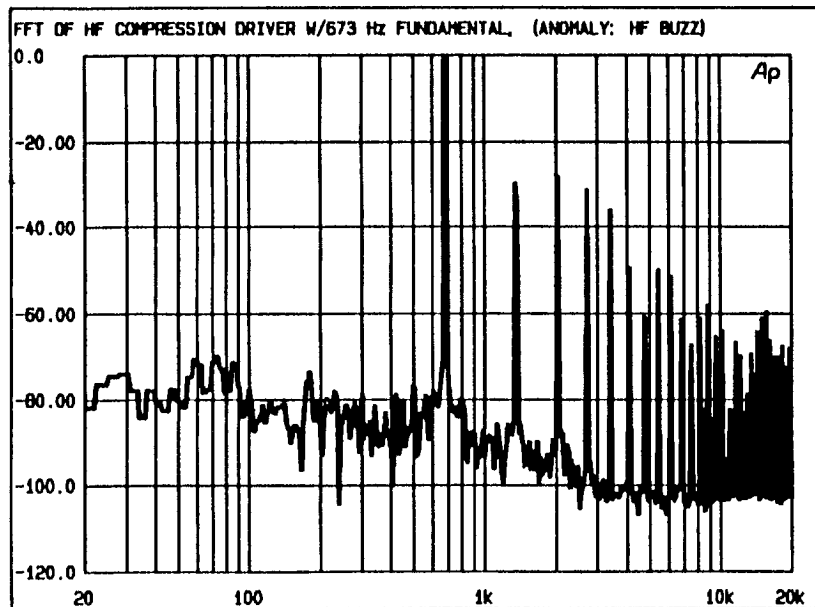

Figure 71: See Section 9.24, 9.26, 10.2

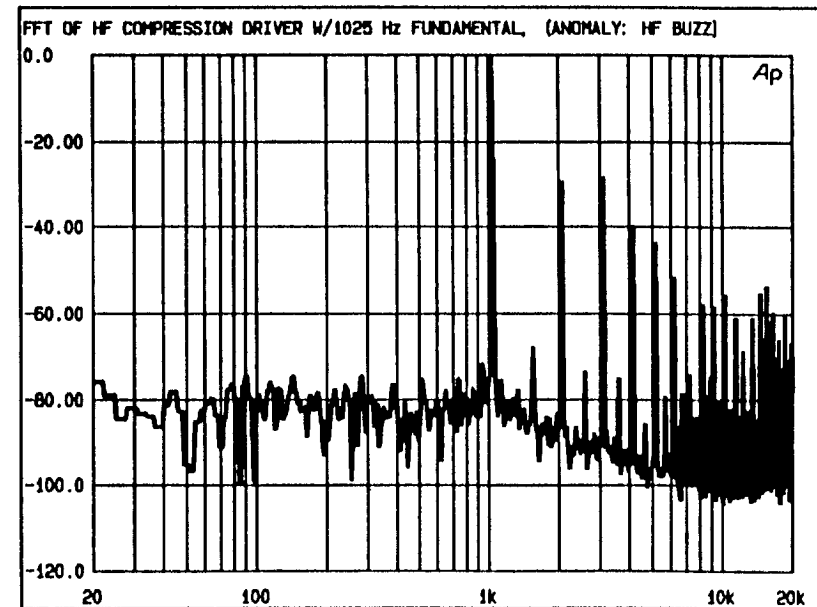

Figure 73: See Section 9.24, 9.26, 10.2

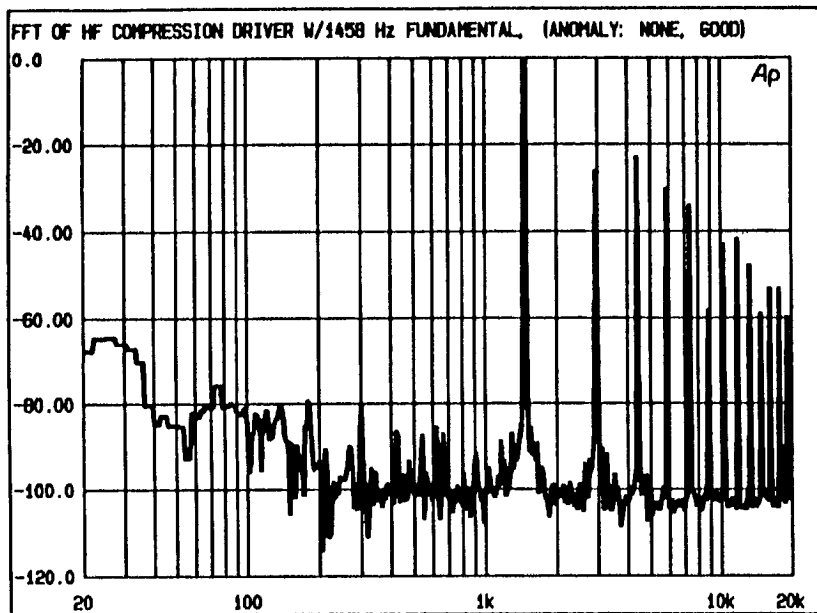

Figure 74: See Section 9.24, 9.26, 10.2

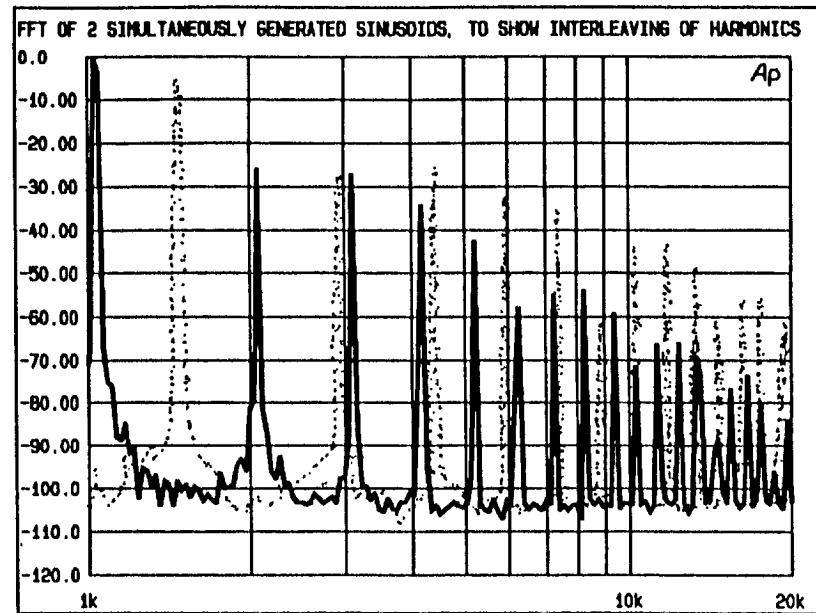

Figure 76: See Section 10.2

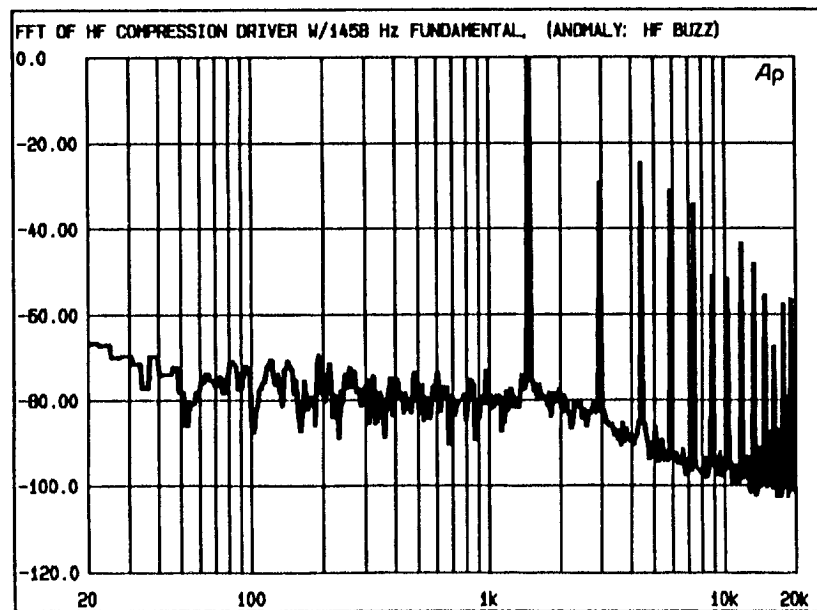

Figure 75: See Section 9.24, 9.26, 10.2

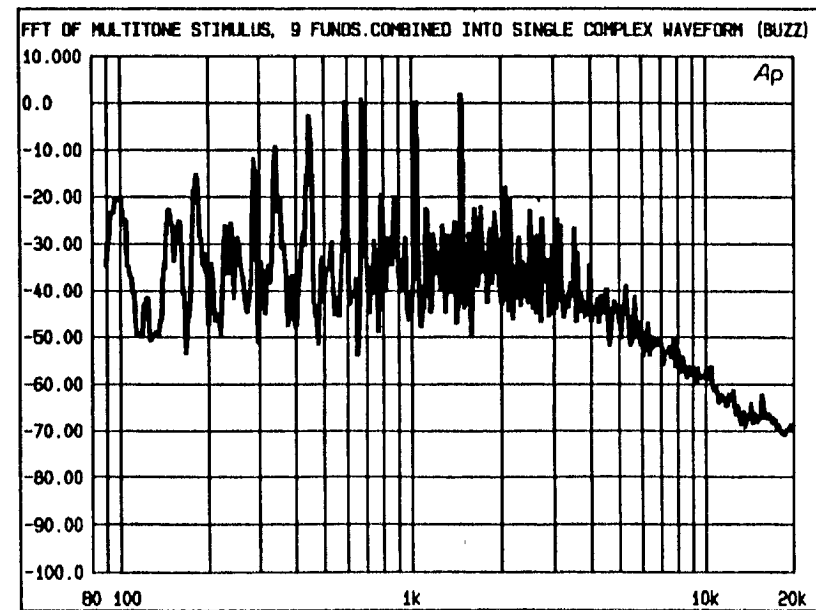

Figure 77: See Section 10.2

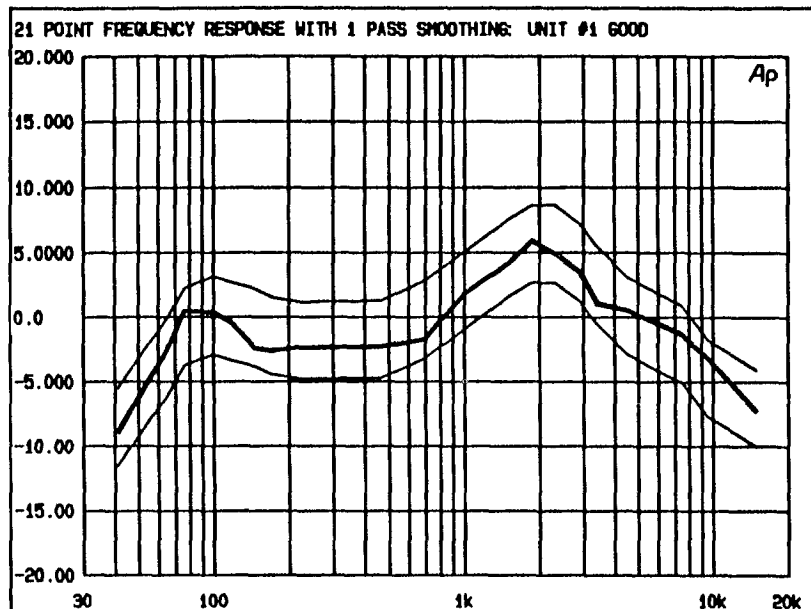

Figure 78: See Section 12.1, 12.4

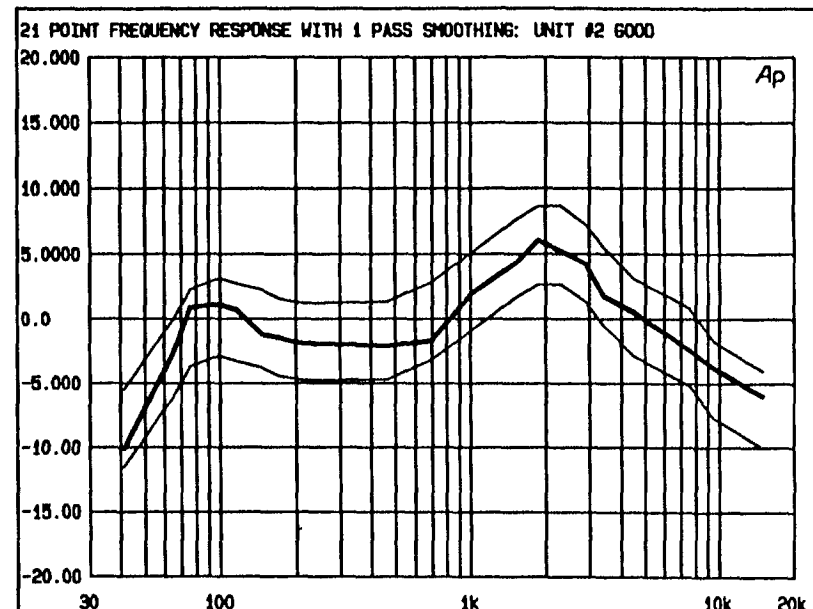

Figure 80: See Section 12.1, 12.4

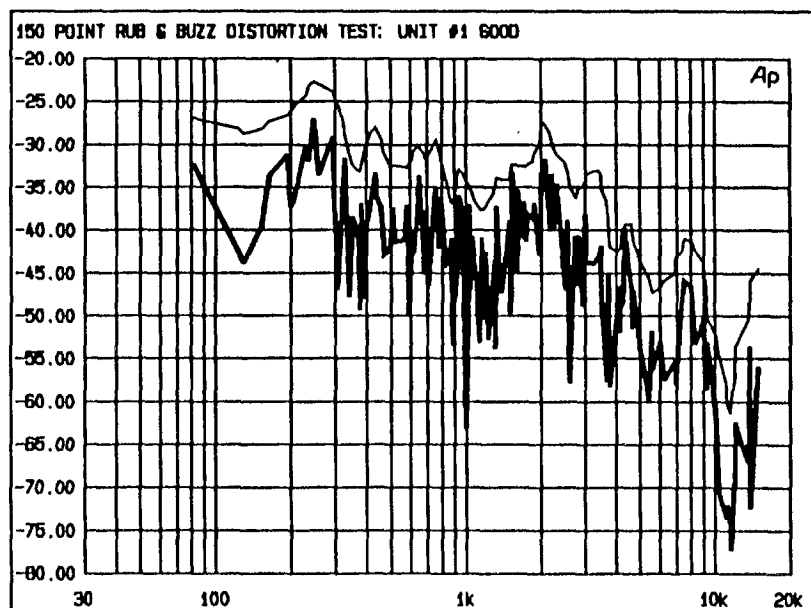

Figure 79: See Section 12.1, 12.4

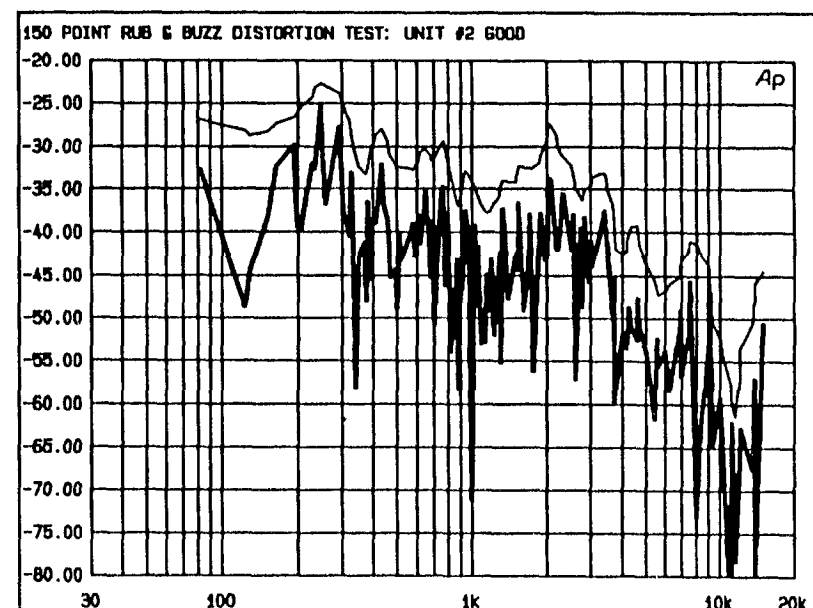

Figure 81: See Section 12.1, 12.4

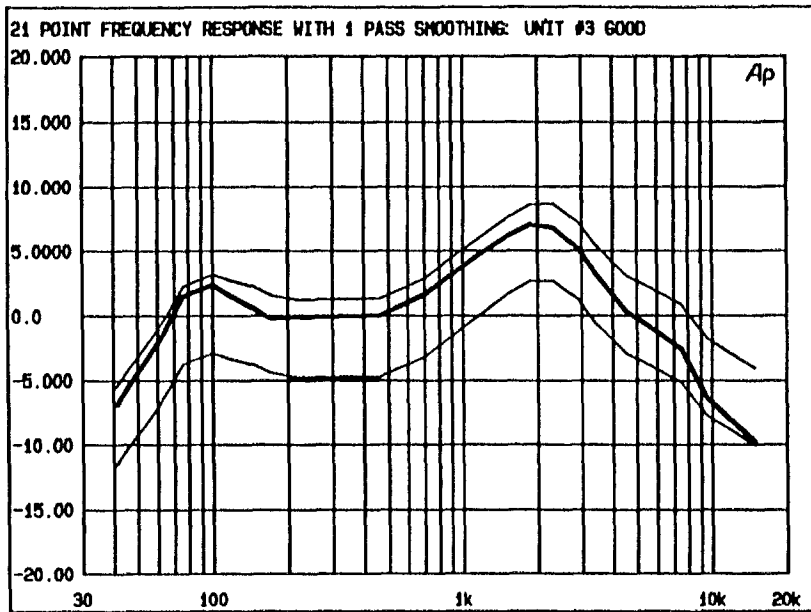

Figure 82: See Section 12.1, 12.4

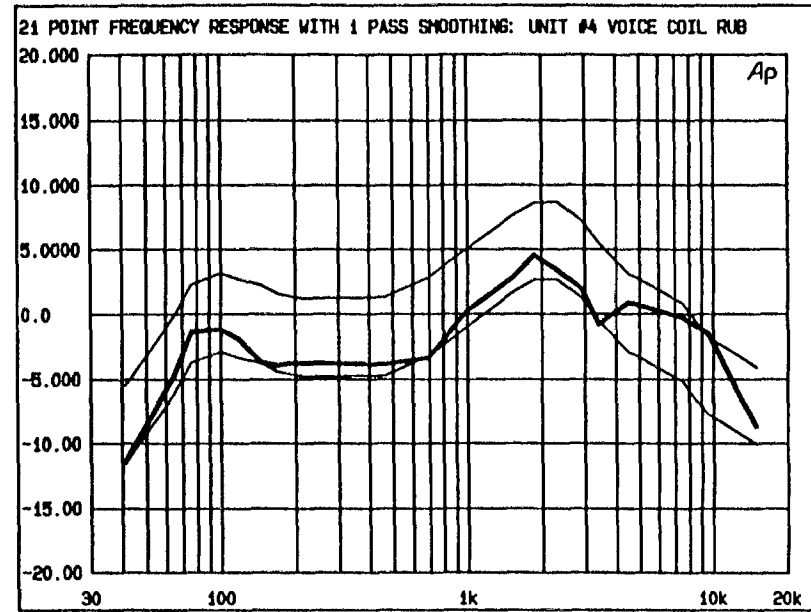

Figure 84: See Section 12.1, 12.4

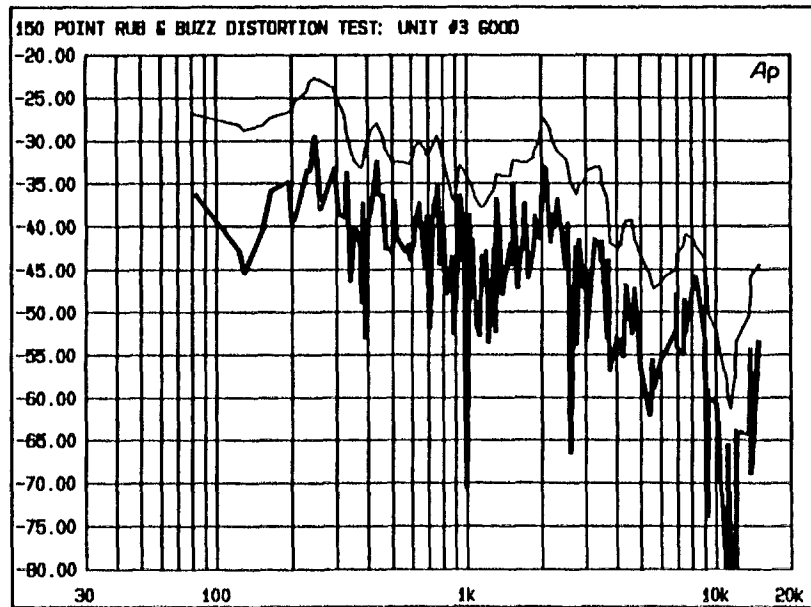

Figure 83: See Section 12.1, 12.4

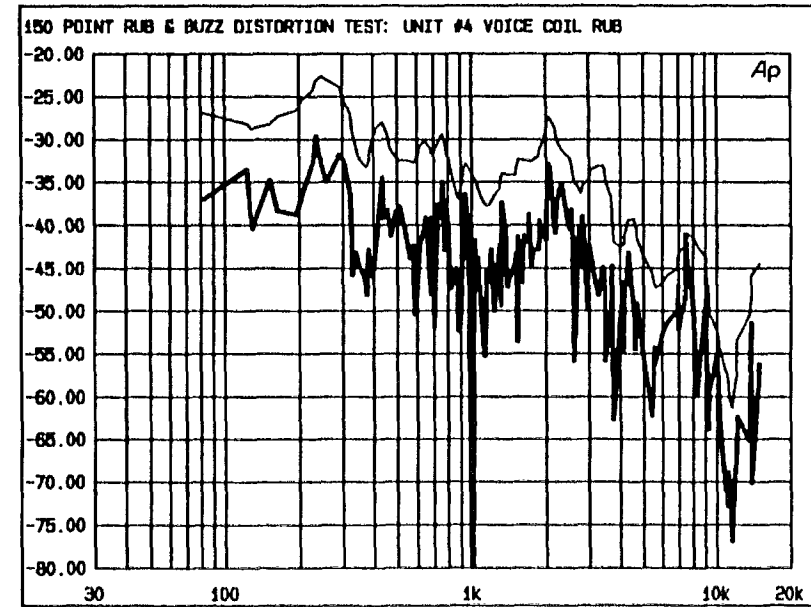

Figure 85: See Section 12.1, 12.4

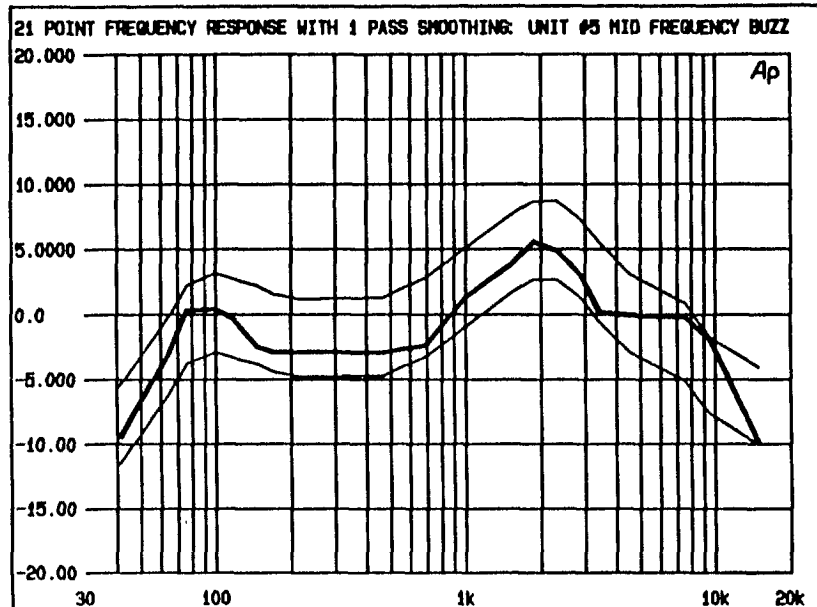

Figure 86: See Section 12.1, 12.4

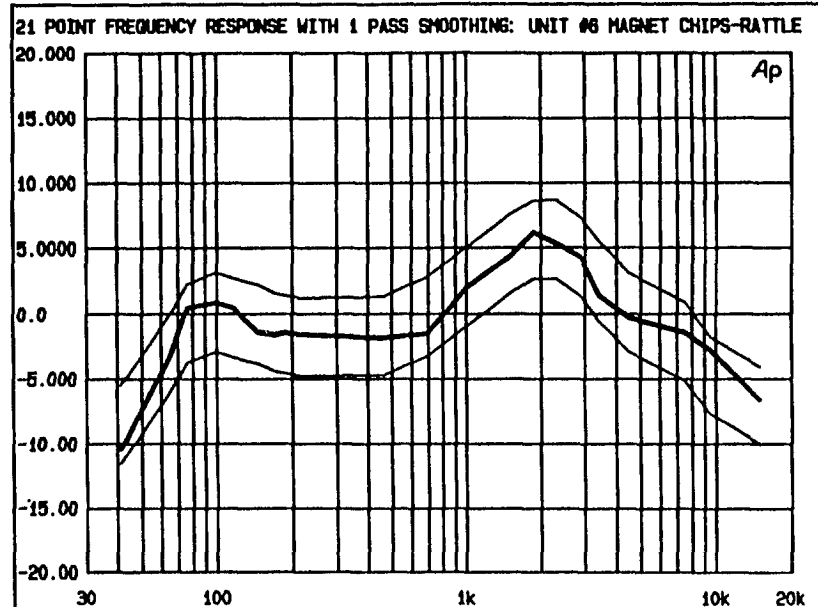

Figure 88: See Section 12.1, 12.4

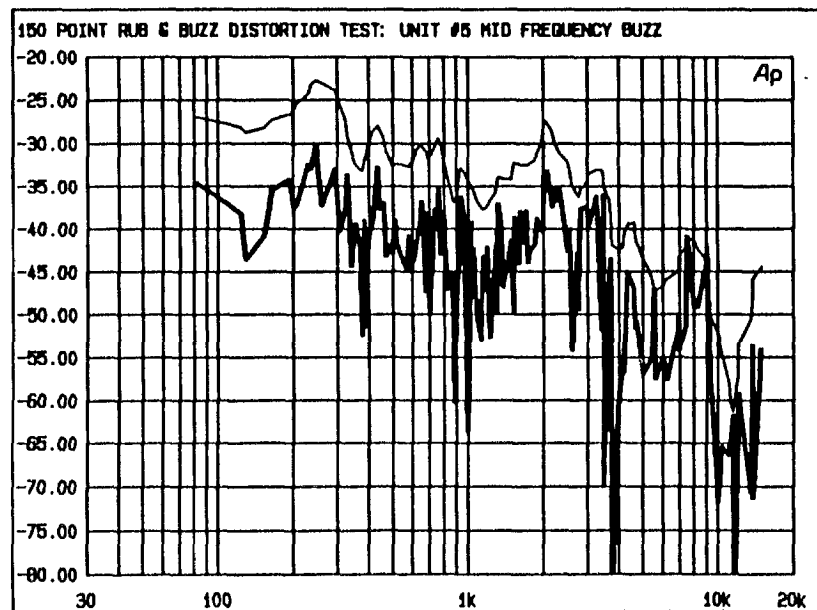

Figure 87: See Section 12.1, 12.4

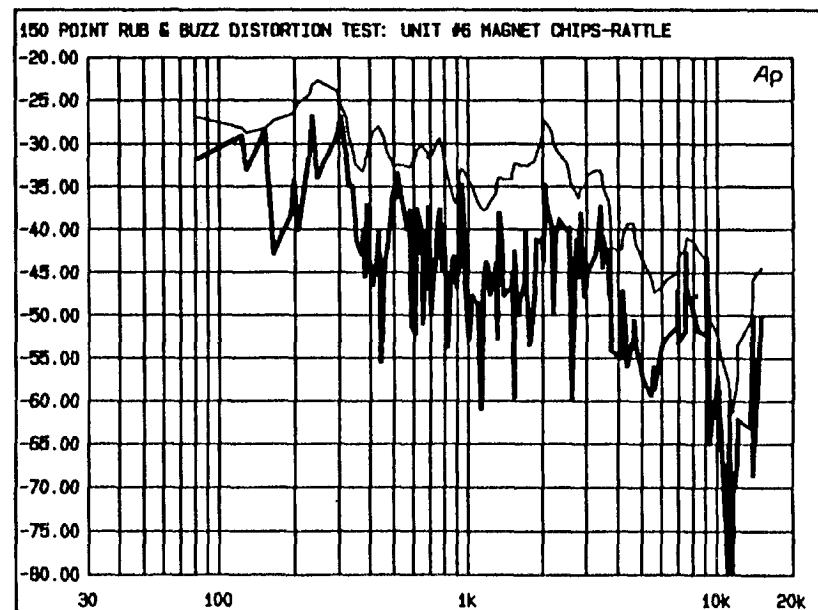

Figure 89: See Section 12.1, 12.4

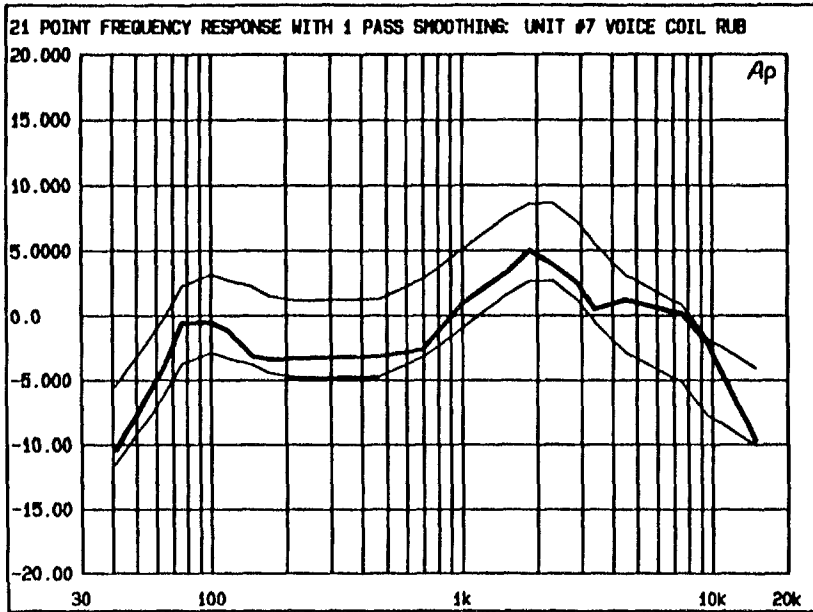

Figure 90: See Section 12.1, 12.4

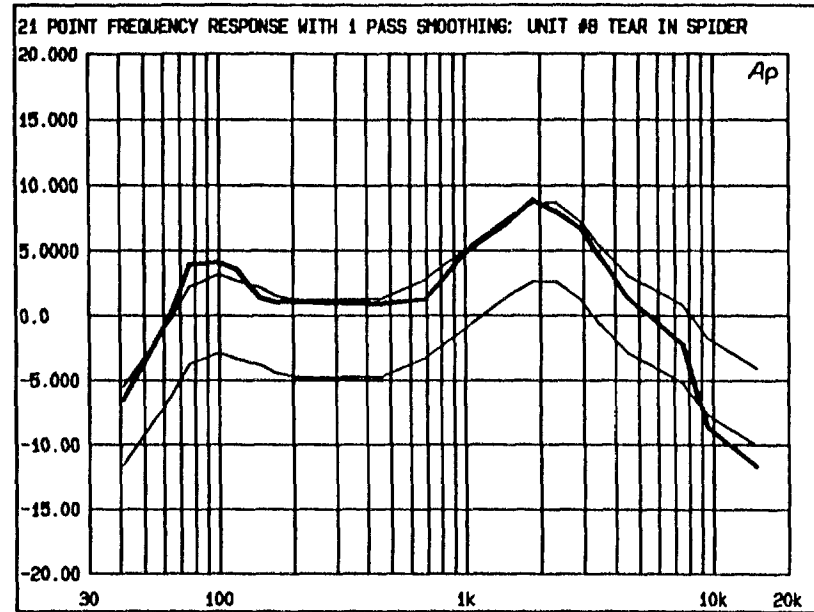

Figure 92: See Section 12.1, 12.4

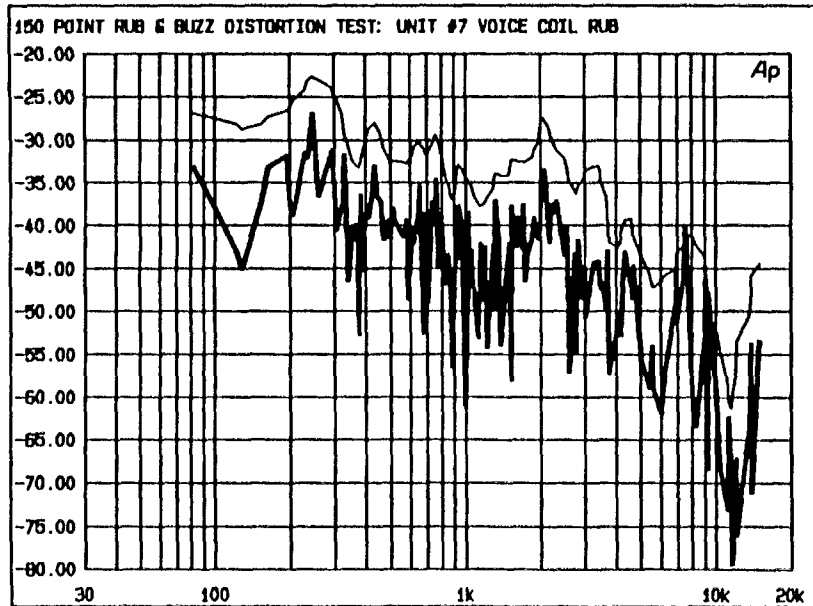

Figure 91: See Section 12.1, 12.4

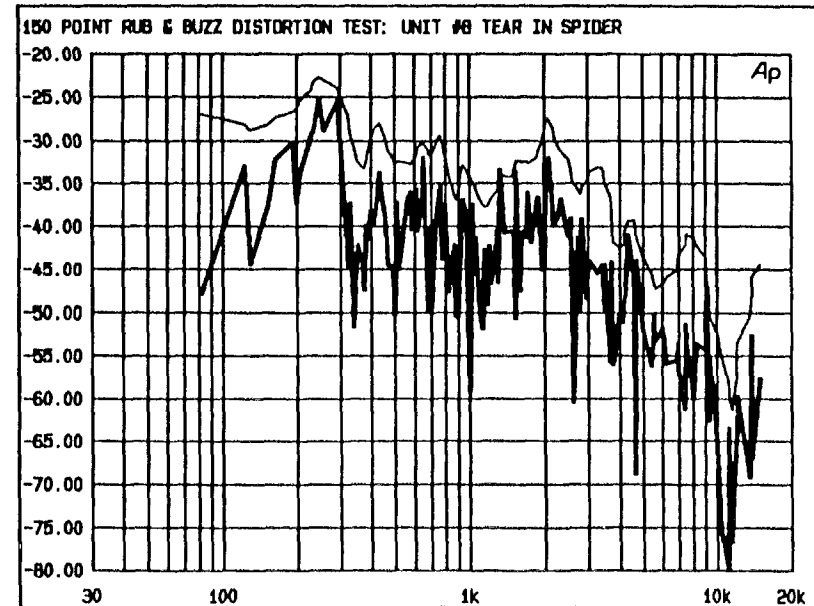
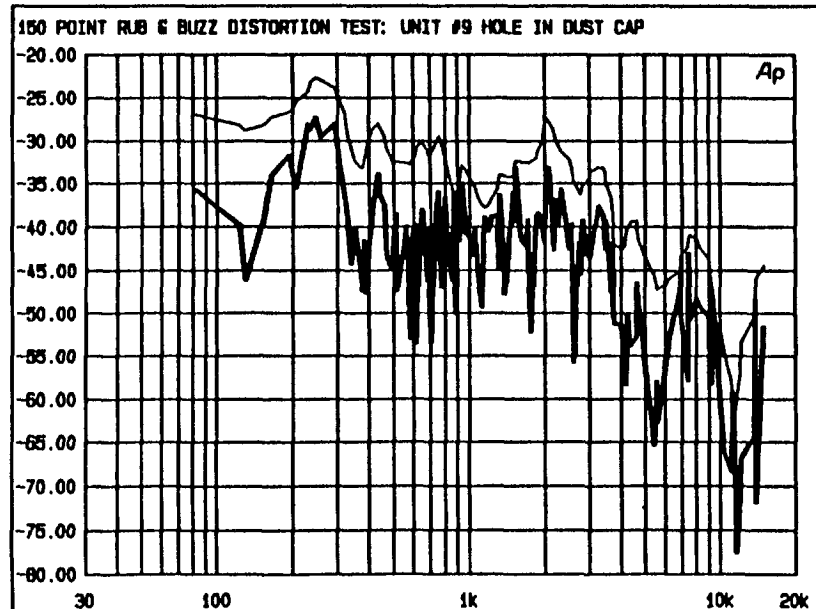
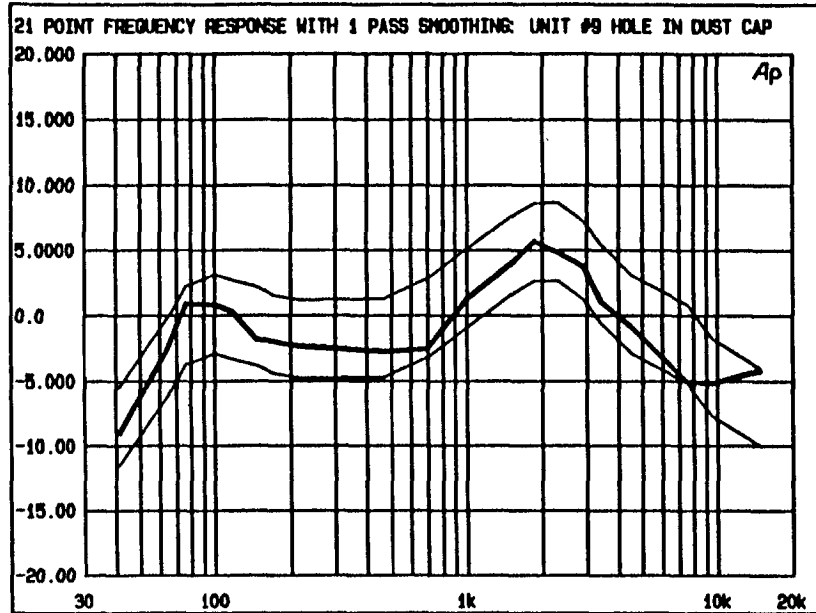

Figure 93: See Section 12.1, 12.4



21SP-U	06	JUL 91	00:50:03	NONE(OFF)	BANDPASS(dBr)	PHASE(deg)
				OFF	+113.00 dBr	+15.0 deg
21SP-L	06	JUL 91	00:50:03	NONE(OFF)	BANDPASS(dBr)	PHASE(deg)
				OFF	+107.00 dBr	-15.0 deg
SP#1	07	JUL 91	02:06:07	NONE(OFF)	BANDPASS(dBr)	PHASE(deg)
				OFF	+107.99 dBr	-1.0 deg
SP#2	07	JUL 91	02:08:26	NONE(OFF)	BANDPASS(dBr)	PHASE(deg)
				OFF	+107.30 dBr	-1.6 deg
SP#3	07	JUL 91	02:09:19	NONE(OFF)	BANDPASS(dBr)	PHASE(deg)
				OFF	+107.70 dBr	-9.6 deg
SP#4	07	JUL 91	02:10:37	NONE(OFF)	BANDPASS(dBr)	PHASE(deg)
				OFF	+107.95 dBr	+4.9 deg
SP#5	07	JUL 91	02:12:28	NONE(OFF)	BANDPASS(dBr)	PHASE(deg)
				OFF	+107.62 dBr	+1.1 deg
SP#6	07	JUL 91	02:13:49	NONE(OFF)	BANDPASS(dBr)	PHASE(deg)
				OFF	+108.03 dBr	-1.3 deg
SP#7	07	JUL 91	02:15:25	NONE(OFF)	BANDPASS(dBr)	PHASE(deg)
				OFF	+107.76 dBr	+4.6 deg
SP#8	07	JUL 91	02:24:12	NONE(OFF)	BANDPASS(dBr)	PHASE(deg)
				OFF	+107.98 dBr	-13.7 deg
SP#9	07	JUL 91	02:26:52	NONE(OFF)	BANDPASS(dBr)	PHASE(deg)
				OFF	+107.26 dBr	-0.3 deg

Figure 96: See Section 12.1, 12.3

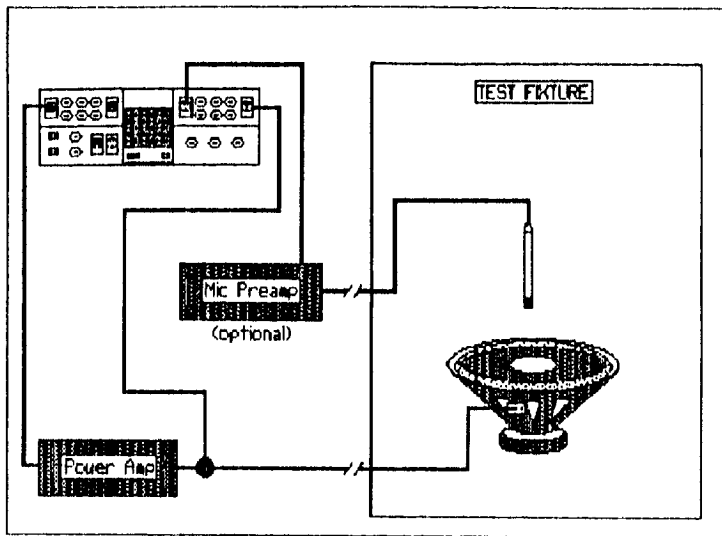

Figure 97: See Section A2.1, 9.4, 9.24, 12.1

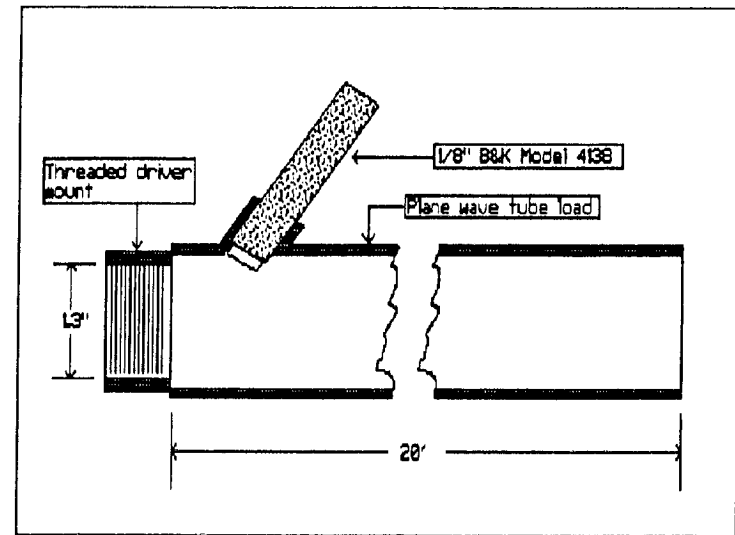

Figure 99: See Section A2.3, 9.24

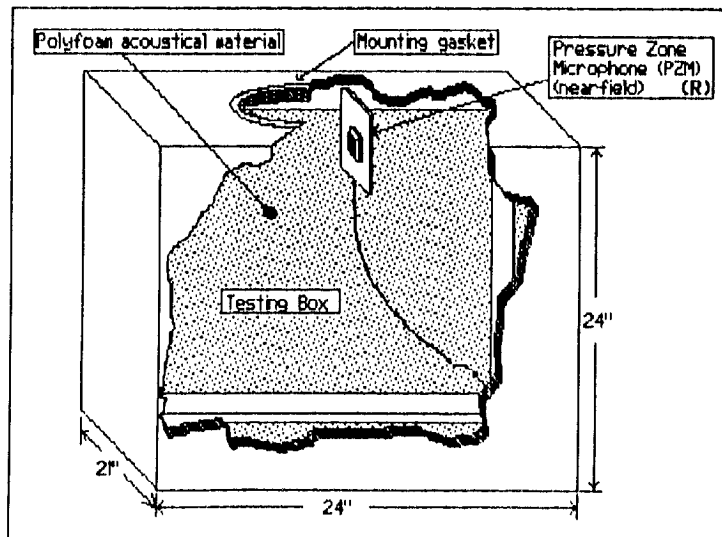

Figure 98: See Section A2.2, 9.4, 12.1

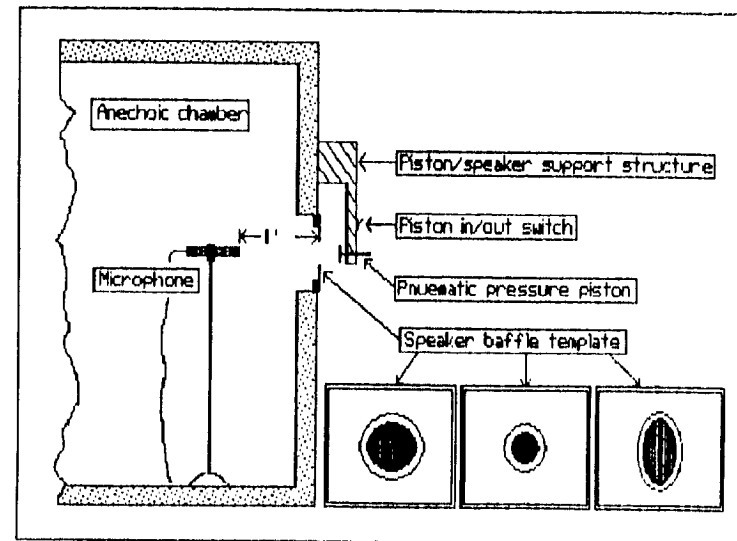

Figure 100: See Section A2.4

9AES.dat

Hz	dBV	deg
99,	-5.55999982,	0
181,	-5.40999966,	40
287,	-4.95999991,	120
339,	-3.59999962,	80
445,	-0.239999777,	160
591,	1.79999986,	240
673,	2.12000018,	200
1025,	2.34000022,	280
1458,	2.34000022,	320

Table 1: See Section 10.2

Original input data file used to create waveform and .daf file for compression driver testing. Note that to conform with a desired input EQ curve, amplitude values have been entered into column two, and to reduce crest factor, the relative phase of each component has been randomized.

9AES.daf

Hz	dBV	deg
99.609375,	-5.55999982,	0
181.640625,	-5.40999966,	40
287.109375,	-4.95999991,	120
339.84375,	-3.59999962,	80
445.3125,	-0.239999777,	160
591.796875,	1.79999986,	240
673.828125,	2.12000018,	200
1025.39062,	2.34000022,	280
1458.98437,	2.34000022,	320

Table 2: See Section 10.2

Actual frequency, amplitude and phase information of the waveform as generated by MAKEWAVE.exe, for the compression driver test.

9H-AES.dad

(cont.)			(cont.)					
Hz	dBV	OFF	Hz	dBV	OFF			
199.21875,	1,		2226.5625,	1,		5789.0625,	1,	
298.828125,	1,		2296.875,	1,		5835.9375,	1,	
363.28125,	1,		2361.32812,	1,		5917.96875,	1,	
398.4375,	1,		2367.1875,	1,		6064.45312,	1,	
498.046875,	1,		2378.90625,	1,		6152.34375,	1,	
544.921875,	1,		2542.96875,	1,		6234.375,	1,	
574.21875,	1,		2583.98437,	1,		6509.76562,	1,	
597.65625,	1,		2671.875,	1,		6679.6875,	1,	
679.6875,	1,		2695.3125,	1,		6738.28125,	1,	
697.265625,	1,		2718.75,	1,		7101.5625,	1,	
726.5625,	1,		2724.60937,	1,		7177.73437,	1,	
796.875,	1,		2871.09375,	1,		7294.92187,	1,	
861.328125,	1,		2917.96875,	1,		7412.10937,	1,	
890.625,	1,		2958.98437,	1,		7693.35937,	1,	
896.484375,	1,		3058.59375,	1,		8085.9375,	1,	
908.203125,	1,		3076.17187,	1,		8203.125,	1,	
996.09375,	1,		3117.1875,	1,		8285.15625,	1,	
1019.53125,	1,		3158.20312,	1,		8753.90625,	1,	
1089.84375,	1,		3369.14062,	1,		8759.76562,	1,	
1095.70312,	1,		3398.4375,	1,		8876.95312,	1,	
1148.4375,	1,		3445.3125,	1,		9228.51562,	1,	
1183.59375,	1,		3550.78125,	1,		9433.59375,	1,	
1195.3125,	1,		3562.5,	1,		10107.4219,	1,	
1271.48437,	1,		3732.42187,	1,		10212.8906,	1,	
1294.92187,	1,		3738.28125,	1,		10253.9062,	1,	
1335.9375,	1,		4007.8125,	1,		11279.2969,	1,	
1347.65625,	1,		4019.53125,	1,		11671.875,	1,	
1359.375,	1,		4042.96875,	1,		12304.6875,	1,	
1394.53125,	1,		4078.125,	1,		13130.8594,	1,	
1435.54687,	1,		4101.5625,	1,		13330.0781,	1,	
1453.125,	1,		4142.57812,	1,		14355.4688,	1,	
1494.14062,	1,		4306.64062,	1,		14589.8438,	1,	
1634.76562,	1,		4376.95312,	1,		15380.8594,	1,	
1699.21875,	1,		4417.96875,	1,		16048.8281,	1,	
1722.65625,	1,		4453.125,	1,		17507.8125,	1,	
1775.39062,	1,		4716.79687,	1,		18966.7969,	1,	
1781.25,	1,		4734.375,	1,		20425.7813,	1,	
1816.40625,	1,		4757.8125,	1,		21884.7656,	1,	
1998.04687,	1,		4898.4375,	1,				
2009.76562,	1,		5097.65625,	1,				
2021.48437,	1,		5126.95312,	1,				
2039.0625,	1,		5326.17187,	1,				
2050.78125,	1,		5343.75,	1,				
2179.6875,	1,		5390.625,	1,				

Table 3: See Section 10.2

Table of distortion components ,2-,14 for 9AES.daf calculated by MAKEDIST.exe

RBF21.dat

Hz	dBV	OFF
41,	0,	0
64,	0,	0
76,	0,	0
100,	0,	0
117,	0,	0
146,	0,	0
169,	0,	0
188,	0,	0
217,	0,	0
462,	0,	0
691,	0,	0
1000,	0,	0
1505,	0,	0
1862,	0,	0
2300,	0,	0
2900,	0,	0
3410,	0,	0
4494,	0,	0
7512,	0,	0
9500,	0,	0
14900,	0,	0

Table 4: See Section 10.6

Original data table used to generate complex waveform used in RBF21 series tests and procedures. Note that column one provides frequency input, column two the amplitude of each frequency and column three the phase of each frequency. Thus, this waveform will have 21 frequencies of equal amplitude and phase.

RBF21.daf

Hz	dBV	OFF
41.015625,	0,	0
64.453125,	0,	0
76.171875,	0,	0
99.609375,	0,	0
117.1875,	0,	0
146.484375,	0,	0
169.921875,	0,	0
187.5,	0,	0
216.796875,	0,	0
462.890625,	0,	0
691.40625,	0,	0
1001.95312,	0,	0
1505.85937,	0,	0
1863.28125,	0,	0
2302.73437,	0,	0
2900.39063,	0,	0
3410.15625,	0,	0
4494.14062,	0,	0
7511.71875,	0,	0
9498.04687,	0,	0
14900.3906,	0,	0

Table 5: See Section 10.7.0

Actual frequencies of complex waveform as created by MAKEWAVE.exe program for DSP signal generator, based on original data table RBF21.dat.

RBF21-6.dat

Hz	dBV	OFF
41.015625,	0,	0
64.453125,	0,	0
76.171875,	0,	0
99.609375,	0,	0
117.1875,	0,	0
146.484375,	0,	0
169.921875,	0,	0
187.5,	0,	0
216.796875,	0,	0
462.890625,	0,	0
691.40625,	0,	0
1001.95312,	0,	0
1505.85937,	0,	0
1863.28125,	0,	0
2302.73437,	0,	0

Table 6: See Section 10.7.1

Here, the top 6 frequencies have been deleted from waveform source file RBF21.daf to create a modified data table to be used to compute the specific harmonics to be evaluated for Rub and Buzz testing.

Hz	dBV	OFF
82.03125,	1,	0
123.046875,	1,	0
128.90625,	1,	0
152.34375,	1,	0
164.0625,	1,	0
193.359375,	1,	0
199.21875,	1,	0
205.078125,	1,	0
228.515625,	1,	0
234.375,	1,	0
257.8125,	1,	0
292.96875,	1,	0
298.828125,	1,	0
304.6875,	1,	0
322.265625,	1,	0
339.84375,	1,	0
351.5625,	1,	0
375,	1,	0
380.859375,	1,	0
398.4375,	1,	0
433.59375,	1,	0
439.453125,	1,	0
468.75,	1,	0
498.046875,	1,	0
509.765625,	1,	0
562.5,	1,	0
585.9375,	2,	0
650.390625,	1,	0
679.6875,	1,	0
732.421875,	1,	0
750,	1,	0
849.609375,	1,	0
867.1875,	1,	0
925.78125,	1,	0
937.5,	1,	0
1083.98437,	1,	0
1382.8125,	1,	0
1388.67187,	1,	0
1851.5625,	1,	0
2003.90625,	1,	0
2074.21875,	1,	0
2314.45312,	1,	0
2765.625,	1,	0
3005.85937,	1,	0
3011.71875,	1,	0
3457.03125,	1,	0
3726.5625,	1,	0
4007.8125,	1,	0
4517.57812,	1,	0
4605.46875,	1,	0
5009.76563,	1,	0
5589.84375,	1,	0
6023.4375,	1,	0
6908.20312,	1,	0
7453.125,	1,	0
7529.29687,	1,	0
9210.9375,	1,	0
9316.40625,	1,	0
11513.6719,	1,	0

Table 7: See Section 10.7.1

Data table generated by MAKEDIST.exe program, of harmonic frequencies ,2-,5 for fundamental frequencies found in RBF21-6.dat.

Hz	dBV	OFF
82.03125,	1,	0
123.046875,	1,	0
128.90625,	1,	0
152.34375,	1,	0
164.0625,	1,	0
193.359375,	1,	0
199.21875,	1,	0
205.078125,	1,	0
228.515625,	1,	0
234.375,	1,	0
257.8125,	1,	0
292.96875,	1,	0
298.828125,	1,	0
304.6875,	1,	0
322.265625,	1,	0
339.84375,	1,	0
351.5625,	1,	0
375,	1,	0
380.859375,	1,	0
398.4375,	1,	0
433.59375,	1,	0
439.453125,	1,	0
468.75,	1,	0
498.046875,	1,	0
509.765625,	1,	0
562.5,	1,	0
585.9375,	2,	0
650.390625,	1,	0
679.6875,	1,	0
732.421875,	1,	0
750,	1,	0
849.609375,	1,	0
867.1875,	1,	0
925.78125,	1,	0
937.5,	1,	0
1083.98437,	1,	0
1382.8125,	1,	0
1388.67187,	1,	0
1851.5625,	1,	0
2003.90625,	1,	0
2074.21875,	1,	0
2314.45312,	1,	0
2765.625,	1,	0
3005.85937,	1,	0
3011.71875,	1,	0
3457.03125,	1,	0
3726.5625,	1,	0
4007.8125,	1,	0
4517.57812,	1,	0
4605.46875,	1,	0

Table 8: See Section 10.7.1

Modified data table to be used as source file for next step of harmonic calculations. Before proceeding, the top nine frequencies had to be deleted from RBF21-H5.dad in order for the file to conform to the maximum number (50) of frequencies allowed in the source file by the MAKEDIST.exe program.

RBF21H5X.dad

Hz	dBV	OFF	(cont.)	Hz	dBV	OFF	(cont.)	Hz	dBV	OFF	(cont.)	Hz	dBV	OFF
<u>82.03125</u>	1,		<u>732.421875</u>	1,			<u>1875</u>	1,			<u>5589.84375</u>	1,		
<u>123.046875</u>	1,		<u>750</u>	1,			<u>1904.29687</u>	1,			<u>6011.71875</u>	1,		
<u>128.90625</u>	1,		<u>761.71875</u>	1,			<u>1951.17187</u>	1,			<u>6023.4375</u>	1,		
<u>152.34375</u>	1,		<u>773.4375</u>	1,			<u>1992.1875</u>	1,			<u>6222.65625</u>	1,		
<u>164.0625</u>	1,		<u>796.875</u>	1,			<u>2003.90625</u>	1,			<u>6908.20312</u>	1,		
<u>193.359375</u>	1,		<u>820.3125</u>	1,			<u>2039.0625</u>	1,			<u>6914.0625</u>	1,		
<u>199.21875</u>	1,		<u>849.609375</u>	1,			<u>2074.21875</u>	1,			<u>6943.35937</u>	1,		
<u>205.078125</u>	1,		<u>867.1875</u>	1,			<u>2167.96875</u>	1,			<u>7406.25</u>	1,		
<u>228.515625</u>	1,		<u>878.90625</u>	1,			<u>2197.26562</u>	1,			<u>7453.125</u>	1,		
<u>234.375</u>	1,		<u>896.484375</u>	1,			<u>2250</u>	1,			<u>7529.29687</u>	1,		
<u>246.09375</u>	1,		<u>914.0625</u>	1,			<u>2314.45312</u>	1,			<u>8015.625</u>	1,		
<u>257.8125</u>	1,		<u>925.78125</u>	1,			<u>2343.75</u>	1,			<u>8296.875</u>	1,		
<u>292.96875</u>	1,		<u>937.5</u>	1,			<u>2490.23437</u>	1,			<u>9017.57812</u>	1,		
<u>298.828125</u>	1,		<u>966.796875</u>	1,			<u>2548.82813</u>	1,			<u>9035.15625</u>	1,		
<u>304.6875</u>	1,		<u>996.09375</u>	1,			<u>2601.5625</u>	1,			<u>9210.9375</u>	1,		
<u>322.265625</u>	1,		<u>1019.53125</u>	1,			<u>2718.75</u>	1,			<u>9257.8125</u>	1,		
<u>328.125</u>	1,		<u>1025.39062</u>	1,			<u>2765.625</u>	1,			<u>9316.40625</u>	1,		
<u>339.84375</u>	1,		<u>1031.25</u>	1,			<u>2777.34375</u>	1,			<u>10019.5312</u>	1,		
<u>351.5625</u>	1,		<u>1054.6875</u>	1,			<u>2812.5</u>	1,			<u>10371.0937</u>	1,		
<u>369.140625</u>	1,		<u>1083.98437</u>	1,			<u>2929.6875</u>	1,			<u>11062.5</u>	1,		
<u>375</u>	1,		<u>1125</u>	1,			<u>3000</u>	1,			<u>11179.6875</u>	1,		
<u>380.859375</u>	1,		<u>1142.57812</u>	1,			<u>3005.85937</u>	1,			<u>11513.6719</u>	1,		
<u>386.71875</u>	1,		<u>1171.875</u>	1,			<u>3011.71875</u>	1,			<u>11572.2656</u>	1,		
<u>398.4375</u>	1,		<u>1195.3125</u>	1,			<u>3251.95312</u>	1,			<u>12023.4375</u>	1,		
<u>410.15625</u>	1,		<u>1218.75</u>	1,			<u>3398.4375</u>	1,			<u>12046.875</u>	1,		
<u>433.59375</u>	1,		<u>1289.0625</u>	1,			<u>3457.03125</u>	1,			<u>13552.7344</u>	1,		
<u>439.453125</u>	1,		<u>1300.78125</u>	1,			<u>3468.75</u>	1,			<u>13816.4062</u>	1,		
<u>457.03125</u>	1,		<u>1318.35937</u>	1,			<u>3662.10937</u>	1,			<u>13828.125</u>	1,		
<u>468.75</u>	1,		<u>1359.375</u>	1,			<u>3703.125</u>	1,			<u>14906.25</u>	1,		
<u>492.1875</u>	1,		<u>1382.8125</u>	1,			<u>3726.5625</u>	1,			<u>15029.2969</u>	1,		
<u>498.046875</u>	1,		<u>1388.67187</u>	1,			<u>3750</u>	1,			<u>15058.5938</u>	1,		
<u>509.765625</u>	1,		<u>1406.25</u>	1,			<u>4007.8125</u>	1,			<u>16031.25</u>	1,		
<u>515.625</u>	1,		<u>1464.84375</u>	1,			<u>4148.4375</u>	1,			<u>17285.1563</u>	1,		
<u>562.5</u>	1,		<u>1494.14062</u>	1,			<u>4166.01562</u>	1,			<u>18070.3125</u>	1,		
<u>580.078125</u>	1,		<u>1500</u>	1,			<u>4248.04687</u>	1,			<u>18421.875</u>	1,		
<u>585.9375</u>	1,		<u>1523.4375</u>	1,			<u>4335.9375</u>	1,			<u>18632.8125</u>	1,		
<u>597.65625</u>	1,		<u>1529.29687</u>	1,			<u>4517.57812</u>	1,			<u>20039.0625</u>	1,		
<u>609.375</u>	1,		<u>1593.75</u>	1,			<u>4605.46875</u>	1,			<u>22587.8906</u>	1,		
<u>615.234375</u>	1,		<u>1611.32812</u>	1,			<u>4628.90625</u>	1,			<u>23027.3438</u>	1,		
<u>644.53125</u>	1,		<u>1667.5</u>	1,			<u>4687.5</u>	1,						
<u>650.390625</u>	1,		<u>1699.21875</u>	1,			<u>5009.76563</u>	1,						
<u>656.25</u>	1,		<u>1734.375</u>	1,			<u>5419.92187</u>	1,						
<u>679.6875</u>	1,		<u>1757.8125</u>	1,			<u>5531.25</u>	1,						
<u>685.546875</u>	1,		<u>1851.5625</u>	1,			<u>5554.6875</u>	1,						

Table 9: See Section 10.7.1

Data file generated by MAKEDIST.exe using RBF21H5-.dat as source file. The /F option was used which combined the frequencies in the source file together along with those newly computed by the MAKEDIST.exe program. As a result, this table represents the harmonics 2-,6 (underlined) of the original 15 frequencies found in RBF21.daf and the harmonics of those harmonics 2-,6.